

Write your name here

Surname

Other names

Pearson Edexcel
Level 1 / Level 2
GCSE (9–1)

Centre Number

| | | | | |
|--|--|--|--|--|
| | | | | |
|--|--|--|--|--|

Candidate Number

| | | | |
|--|--|--|--|
| | | | |
|--|--|--|--|

Mathematics

Paper 2 (Calculator)

Foundation Tier

Thursday 8 June 2017 – Morning

Time: 1 hour 30 minutes

Paper Reference

1MA1/2F

You must have: Ruler graduated in centimetres and millimetres, protractor, pair of compasses, pen, HB pencil, eraser, calculator. Tracing paper may be used.

Total Marks

Instructions

- Use **black** ink or ball-point pen.
- **Fill in the boxes** at the top of this page with your name, centre number and candidate number.
- Answer **all** questions.
- Answer the questions in the spaces provided – *there may be more space than you need.*
- You must **show all your working**.
- Diagrams are **NOT** accurately drawn, unless otherwise indicated.
- **Calculators may be used.**
- If your calculator does not have a π button, take the value of π to be 3.142 unless the question instructs otherwise.



Information

- The total mark for this paper is 80
- The marks for **each** question are shown in brackets – *use this as a guide as to how much time to spend on each question.*

Advice

- Read each question carefully before you start to answer it.
- Keep an eye on the time.
- Try to answer every question.
- Check your answers if you have time at the end.

Turn over ►

P48855A

©2017 Pearson Education Ltd.

6/6/6/6/4/

.CG Maths.
Worked Solutions



Pearson

Please note that these worked solutions have neither been provided nor approved by Pearson Education and may not necessarily constitute the only possible solutions. Please refer to the original mark schemes for full guidance.

Any writing in blue should be written in the exam.

Anything written in green in a rectangle doesn't have to be written in the exam.

If you find any mistakes or have any requests or suggestions, please send an email to curtis@cgmaths.co.uk

Answer ALL questions.

Write your answers in the spaces provided.

You must write down all the stages in your working.

1 (a) Simplify $5p - 3p + p$

$5 - 3 + 1 = 3$, so $5p - 3p + p = 3p$

$3p$

(1)

(b) Simplify $m^3 + m^3$

There are 2 lots of m^3

$2m^3$

(1)

(c) Simplify $10 + 3c + 5d - 7c + d$

Collecting like terms. $3c - 7c = -4c$ and $5d + d = 6d$

$10 - 4c + 6d$

(2)

(Total for Question 1 is 4 marks)

2 Write 56.78 correct to one significant figure.

5 is the 1st significant figure. The 2nd significant figure is a 6 so this means the 1st should round up. Then everything after the 1st figure is set to 0 and is ignored

60

(Total for Question 2 is 1 mark)

DO NOT WRITE IN THIS AREA

DO NOT WRITE IN THIS AREA

DO NOT WRITE IN THIS AREA

DO NOT WRITE IN THIS AREA

DO NOT WRITE IN THIS AREA

DO NOT WRITE IN THIS AREA

3 A teacher asks the students in Year 6 what type of transport they use to get to school. The dual bar chart shows some of the results.

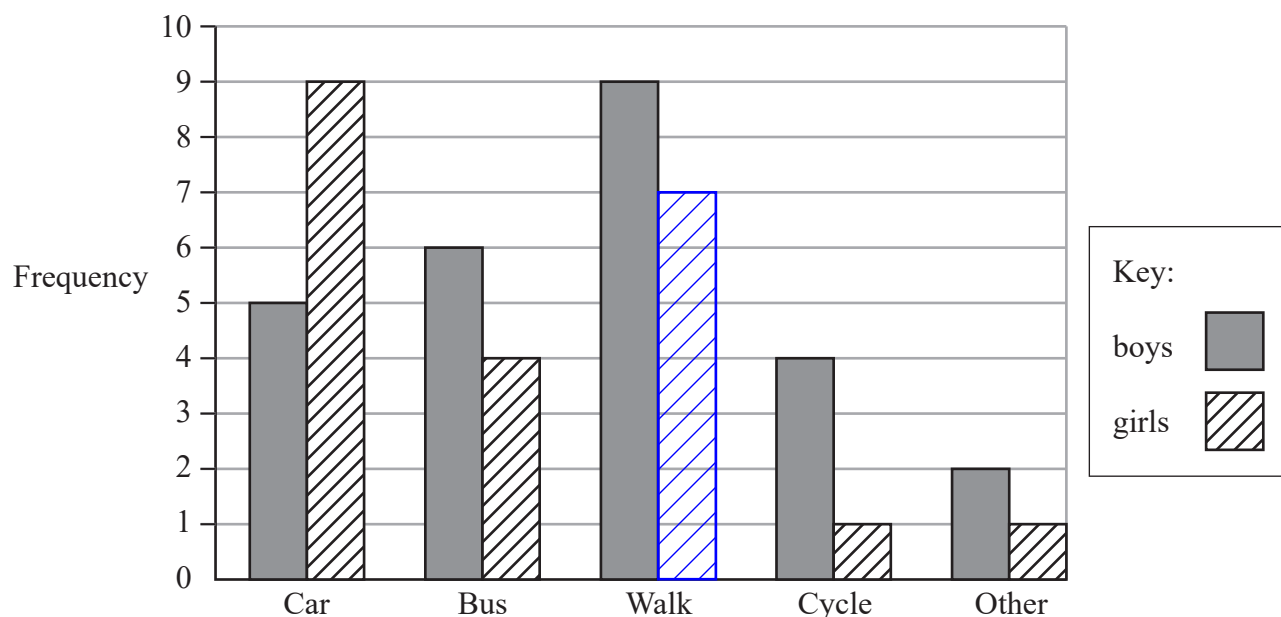

(a) What is the most popular type of transport used by the boys?

Out of the dark grey bars, the bar for walk is the tallest so has the highest frequency

Walk

(1)

7 girls walk to school.

(b) Show this information on the dual bar chart.

(1)

More of the students get to school by car than by bus.

(c) How many more?

14 - 10 ← 5 + 9 = 14 students get to school by car. 6 + 4 = 10 students get to school by bus. Subtracting the 10 from the 14 works out how much more the 14 is

4

(1)

The number of students in Year 5 is the same as the number of students in Year 6

(d) What is the total number of students in Years 5 and 6?

5 + 9 + 6 + 4 + 9 + 7 + 4 + 1 + 2 + 1 ← Adding the frequencies of each bar works out that there are 48 students in Year 6. There must also be 48 in Year 5

48 + 48 ← Adding the 48 in Year 5 and the 48 in Year 6 works out the total

96

(2)

(Total for Question 3 is 5 marks)

4 Here are four fractions.

$$\frac{2}{5}$$

40%

$$\frac{11}{30}$$

36.6%

$$\frac{1}{2}$$

50%

$$\frac{7}{15}$$

46.6%

Write these fractions in order of size.
Start with the smallest fraction.

Multiplying each fraction by 100 converts them to percentages, which are easier to compare

$$\frac{11}{30} \quad \frac{2}{5} \quad \frac{7}{15} \quad \frac{1}{2}$$

(Total for Question 4 is 2 marks)

5 David sells CDs in a shop.

The tally chart shows information about the number of CDs David sold on Monday, on Tuesday and on Wednesday.

| | Tally | Frequency |
|-----------|-------|-----------|
| Monday | | 12 |
| Tuesday | | 18 |
| Wednesday | | 8 |

(a) Write down **one** thing that is wrong with the tally chart.

The frequency and tally for Monday are different

The tally is 13 and the frequency is 12

(1)

David drew this pictogram to show the information for Tuesday and Wednesday.

| | |
|-----------|-----------|
| Tuesday | ⊙ ⊙ ⊙ ⊙ ⊙ |
| Wednesday | ⊙ ⊙ ⊙ |

Key: ⊙ represents 3 CDs

(b) Write down **one** thing that is wrong with this pictogram.

Can't have half a CD

Wednesday represents 7.5 according to the pictogram

(1)

(Total for Question 5 is 2 marks)

6 There are 495 coins in a bottle.

$\frac{1}{3}$ of the coins are £1 coins.

124 of the coins are 50p coins.

The rest of the coins are 20p coins.

Work out the total value of the 495 coins.

$$\frac{1}{3} \times 495 = 165$$

This works out that $\frac{1}{3}$ of the 495 coins is 165.
So there are 165 £1 coins, which are worth £165

$$124 \times 0.50 = 62$$

This works out that 124 50p coins are worth £62. 50p is £0.50

$$495 - 165 - 124$$

Subtracting the 165 £1 coins and the 124 50p coins from the 495 coins works out that there are 206 20p coins

$$206 \times 0.20 = 41.20$$

This works out that 206 20p coins are worth £41.20. 20p is £0.20

$$165 + 62 + 41.20$$

Adding the value of the £1 coins, the value of the 50p coins and the value of the 20p coins works out the total value of the 495 coins

£..... 268.20

(Total for Question 6 is 4 marks)

7 The probability that a new fridge has a fault is 0.015

What is the probability that a new fridge does **not** have a fault?

1 - 0.015

It is certain to either have a fault or not have a fault, so the probabilities must add to 1. Subtracting the probability of having a fault from 1 leaves the probability of not having a fault

0.985

(Total for Question 7 is 1 mark)

8 Here is a list of numbers.

21 22 23 24 25 26 27 28 29

(a) From the numbers in the list, write down a square number.

$5^2 = 5 \times 5 = 25$, so 25 is a square number

25

(1)

(b) From the numbers in the list, write down a number that is a multiple of **both** 4 and 6

24 is in both the 4 and 6 times table

24

(1)

(c) Write down all the prime numbers in the list.

Prime numbers are only divisible by themselves and 1. The calculator can check if a number is prime by expressing them as a product of prime factors. If they do not change they must be prime

23, 29

(1)

(Total for Question 8 is 3 marks)

9

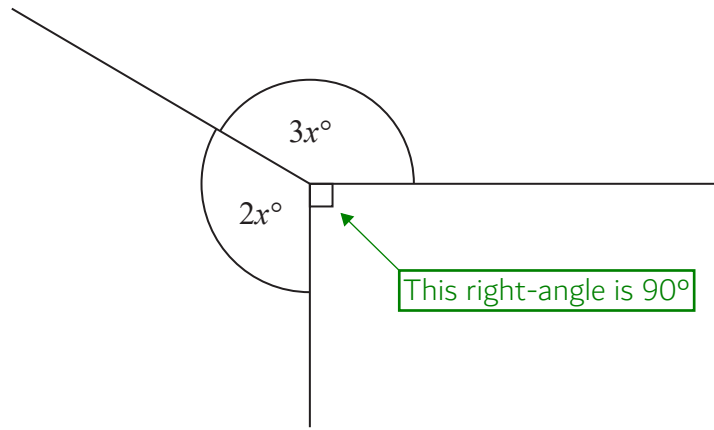

Find the value of x .

$$360 - 90$$

There are 360° around a point. Subtracting the 90° from 360° works out that there are 270° left around the point

$$270 \div 5$$

$2x + 3x = 5x$ is left around the point. So $5x = 270$. Dividing the 270° by 5 finds x

54

(Total for Question 9 is 3 marks)

DO NOT WRITE IN THIS AREA

DO NOT WRITE IN THIS AREA

DO NOT WRITE IN THIS AREA

DO NOT WRITE IN THIS AREA

DO NOT WRITE IN THIS AREA

DO NOT WRITE IN THIS AREA

10 Suha is going to buy 150 envelopes.

Here is some information about the cost of envelopes in two shops.

| |
|--|
| <p>Letters2send</p> <p>Pack of 25 envelopes for £3.49</p> |
|--|

| |
|---|
| <p>Stationery World</p> <p>Pack of 10 envelopes for £2.10</p> <p>Buy 2 packs get 1 pack free</p> |
|---|

Suha wants to buy the envelopes as cheaply as possible.

Which shop should Suha buy the 150 envelopes from?

You must show how you get your answer.

$150 \div 25$ ← This works out that 6 packs of 25 are needed from Letters2send

$3.49 \times 6 = 20.94$ ← This works out that 150 envelopes cost £20.94 from Letters2send

$150 \div 30$ ← Buying 2 packs and getting a free pack is 3 packs in total each time the offer from Stationery World is used. $3 \times 10 = 30$ envelopes each time the offer is used. Dividing the 150 envelopes by 30 works out that the offer needs to be used 5 times

$2.10 \times 2 \times 5 = 21$ ← Multiplying the £2.10 by 2 as 2 packs are bought each time the offer is used. Multiplying this by 5 as the offer needs to be used 5 times. This works out that 150 envelopes cost £21 from Stationery World

Letters2send ← £20.94 is less than £21

(Total for Question 10 is 4 marks)

11 You can use this graph to change between inches and centimetres.

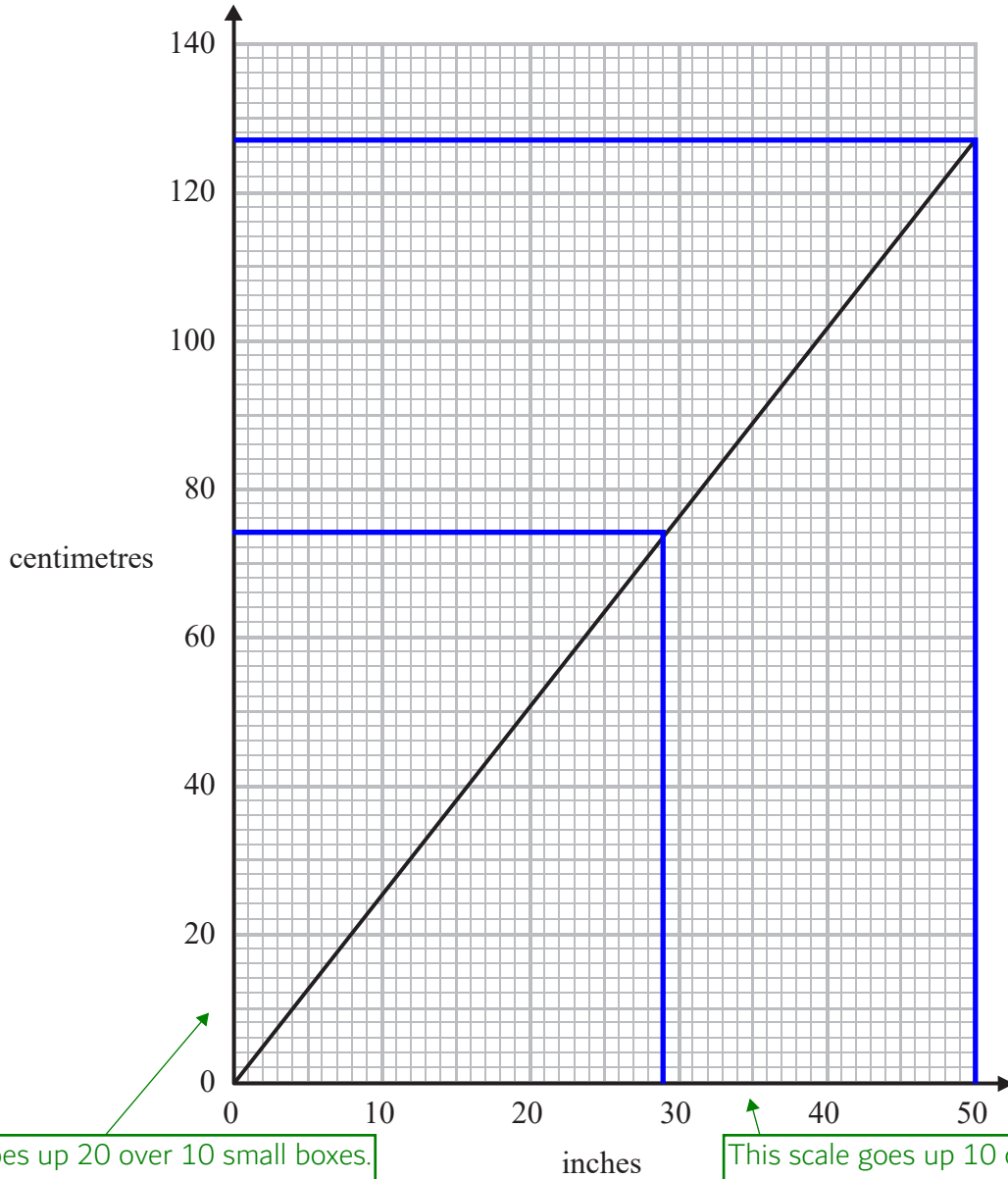

This scale goes up 20 over 10 small boxes.
 $20 \div 10 = 2$, so each small box is worth 2

This scale goes up 10 over 10 small boxes.
 $10 \div 10 = 1$, so each small box is worth 1

(a) Change 74 cm to inches.

Reading across from 74 cm to the line then down to the inches

.....29..... inches
(1)

DO NOT WRITE IN THIS AREA

DO NOT WRITE IN THIS AREA

DO NOT WRITE IN THIS AREA

Daniel's height is 6 feet 3 inches.

1 foot = 12 inches

(b) What is Daniel's height in centimetres?

$$6 \times 12 \leftarrow \text{Multiplying the 6 feet by 12 converts it to 72 inches}$$

$$72 + 3 = 75 \leftarrow \text{Adding the 3 inches works out that Daniel's height is 75 inches}$$

$$127 \div 50 \leftarrow \text{From the graph, 50 inches is 127 cm. Dividing the 127 cm by 50 works out that 1 inch is about 2.54 cm}$$

$$75 \times 2.54 \leftarrow \text{Multiplying the 75 inches by 2.54 converts it to centimetres}$$

.....190.5..... centimetres
(3)

(Total for Question 11 is 4 marks)

12 Find the value of $\frac{\sqrt{13.4 - 1.5}}{(6.8 + 0.06)^2}$

Write down all the figures on your calculator display.

Type it into the calculator exactly as it is above

.....0.07330359081.....

(Total for Question 12 is 2 marks)

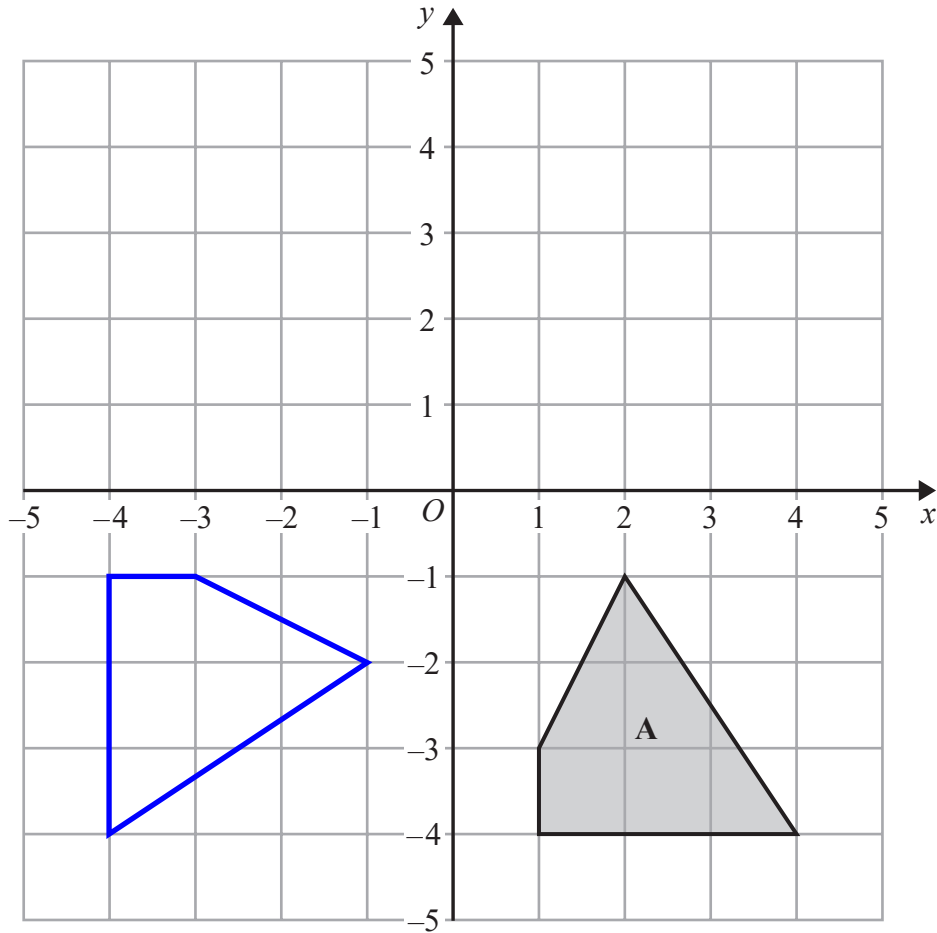

(a) Rotate shape A 90° clockwise about centre O .

(2)

Use tracing paper to sketch around A. Put something sharp in the tracing paper at O then rotate the paper 90° clockwise

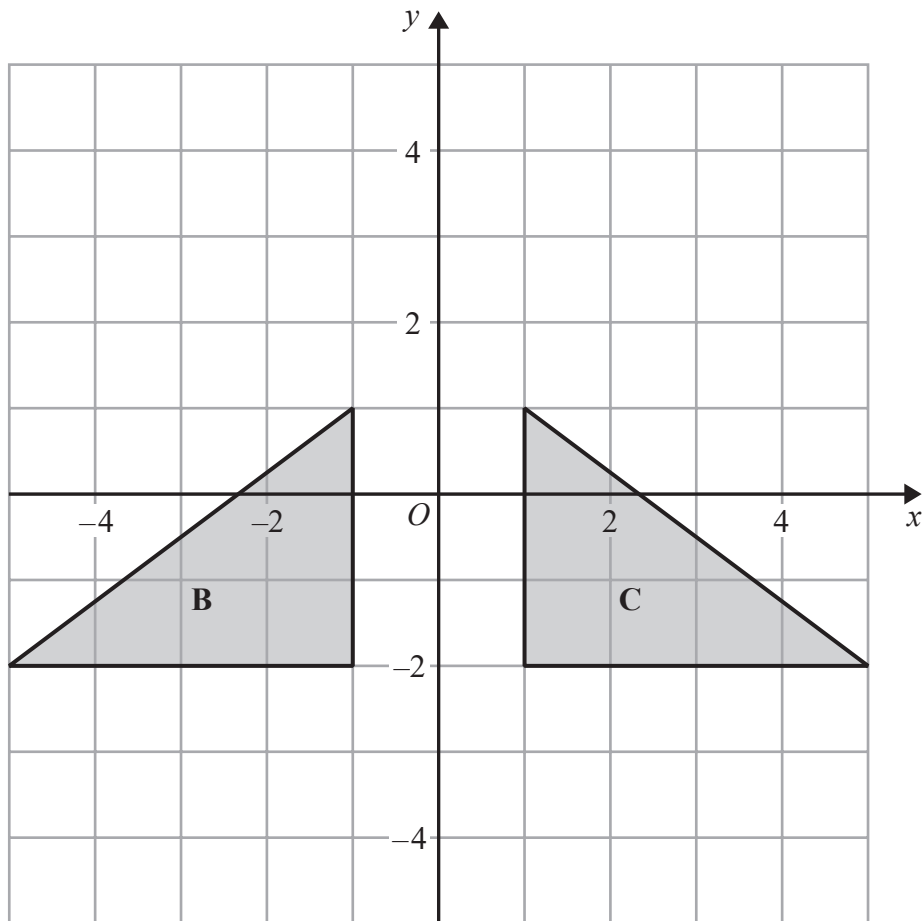

(b) Describe fully the single transformation that maps triangle **B** onto triangle **C**.

Reflection in the y-axis

C is a mirror image of B so it is a reflection. The y-axis is halfway between both shapes so it must be reflecting on this line

(2)

(Total for Question 13 is 4 marks)

14 (a) Factorise $5 - 10m$

5 is the highest common factor of both 5 and $-10m$, so is brought out as a factor. Both terms are divided by 5 and the result is left in a bracket

$$5(1 - 2m)$$

(1)

(b) Factorise fully $2a^2b + 6ab^2$

$2ab$ is the highest common factor of both terms, so is brought out as a factor. Both terms are divided by $2ab$ and the result is left in a bracket

$$2ab(a + 3b)$$

(2)

(Total for Question 14 is 3 marks)

15 (a) Write 4.7×10^{-1} as an ordinary number.

Type it into the calculator and format as a decimal

$$0.47$$

(1)

(b) Work out the value of $(2.4 \times 10^3) \times (9.5 \times 10^5)$
Give your answer in standard form.

Type it into the calculator and format as ENG notation. This does not always put it into standard form but does in this case

$$2.28 \times 10^9$$

(2)

(Total for Question 15 is 3 marks)

DO NOT WRITE IN THIS AREA

DO NOT WRITE IN THIS AREA

DO NOT WRITE IN THIS AREA

16 A , B and C are three points on a map.

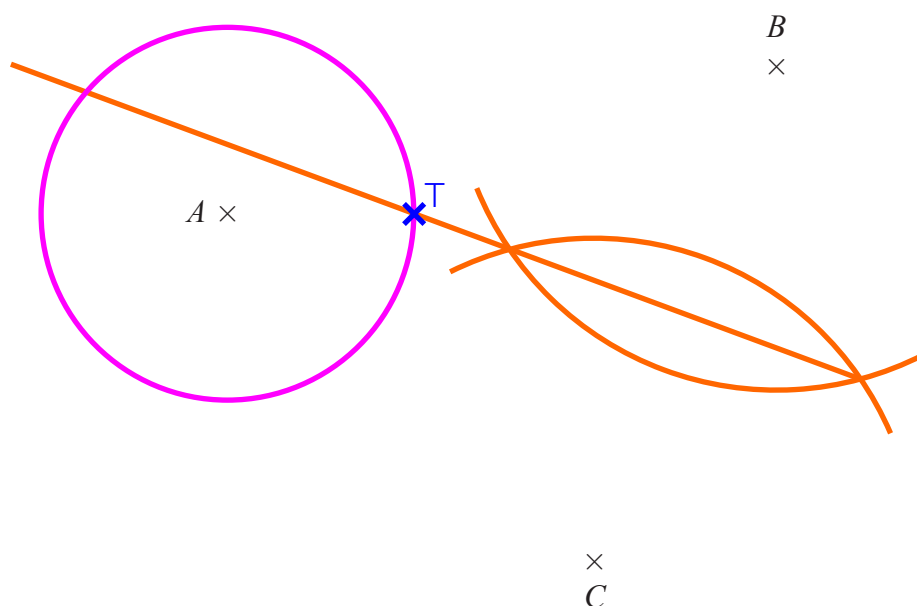

1 cm represents 100 metres.

Point T is 250 metres from point A .

Point T is equidistant from point B and point C .

On the map, show one of the possible positions for point T .

(Total for Question 16 is 3 marks)

Using a compass, draw a circle around A with a radius of 2.5 cm (shown in pink). This represents all points which are 250 metres from point A .

Using a compass and ruler, construct a perpendicular bisector of BC (shown in orange). This represents all points which are equidistant from point B and point C .

T can be where both the circle in pink and the straight line in orange intersect

17 The table shows the probabilities that a biased dice will land on 2, on 3, on 4, on 5 and on 6

| Number on dice | 1 | 2 | 3 | 4 | 5 | 6 |
|----------------|---|------|------|------|------|-----|
| Probability | | 0.17 | 0.18 | 0.09 | 0.15 | 0.1 |

Neymar rolls the biased dice 200 times.

Work out an estimate for the total number of times the dice will land on 1 or on 3

$1 - 0.17 - 0.09 - 0.15 - 0.1$ ← It is certain to be one of the numbers on the dice so all of the probabilities must add up to 1. So subtracting the probabilities for the numbers 2, 4, 5 and 6 from 1 works out that the probability for the number 1 or number 3 is 0.49

200×0.49 ← Multiplying the total frequency the probability of landing on 1 or 3 gives an estimate for the number of times it will land on a 1 or 3.

98

(Total for Question 17 is 3 marks)

DO NOT WRITE IN TH

DO NOT WRITE IN THIS AREA

DO NOT WRITE IN THIS AREA

- 18 On Saturday, some adults and some children were in a theatre.
The ratio of the number of adults to the number of children was 5 : 2

Each person had a seat in the Circle or had a seat in the Stalls.

$\frac{3}{4}$ of the children had seats in the Stalls.

117 children had seats in the Circle.

There are exactly 2600 seats in the theatre.

On this Saturday, were there people on more than 60% of the seats?
You must show how you get your answer.

$$\frac{60}{100} \times 2600 = 1560$$

Putting the 60% over 100 converts it to a fraction. Multiplying this fraction by the 2600 seats works out that 60% of the seats is 1560

$$1 - \frac{3}{4}$$

There was 1 lot of children. Subtracting the $\frac{3}{4}$ which had seats in the Stalls works out that $\frac{1}{4}$ of the children had a seat in the Circle

$$117 \times 4$$

The opposite of doing $\frac{1}{4}$ is multiplying by 4. So multiplying the 117 children in the Circle by 4 works out that there were 468 children

$$468 \div 2$$

2 parts of the ratio represent the children. So dividing the 468 children by 2 works out that 1 part of the ratio is worth 234

$$234 \times 7 = 1638$$

$5 + 2 = 7$ parts in total in the ratio. Multiplying the value of 1 part of the ratio by 7 works out that there were 1638 people in total

Yes

1638 people is more than the 1560 seats (which was 60% of the seats)

(Total for Question 18 is 5 marks)

19 The diagram shows a prism with a cross section in the shape of a trapezium.

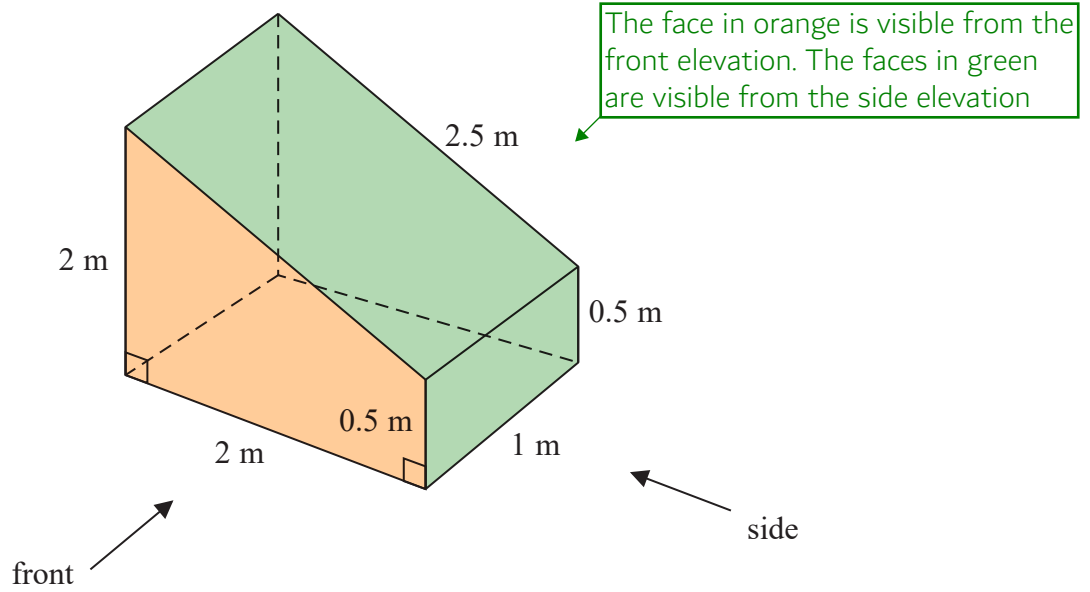

On the centimetre grid below, draw the front elevation and the side elevation of the prism. Use a scale of 2 cm to 1 m.

So multiply all the lengths in metres by 2 to work out how many centimetres represent it

(Total for Question 19 is 4 marks)

DO NOT WRITE IN THIS AREA

DO NOT WRITE IN THIS AREA

DO NOT WRITE IN THIS AREA

DO NOT WRITE IN THIS AREA

20 Olly drove 56 km from Liverpool to Manchester.
He then drove 61 km from Manchester to Sheffield.

Olly's average speed from Liverpool to Manchester was 70 km/h.
Olly took 75 minutes to drive from Manchester to Sheffield.

(a) Work out Olly's average speed for his total drive from Liverpool to Sheffield.

$s \quad d \quad t$ ← Writing the formula triangle for speed, distance, time

$56 + 61 = 117$ ← Adding the distance from Liverpool to Manchester and the distance from Manchester to Sheffield works out that the total distance from Liverpool to Sheffield is 117 km

$56 \div 70 = 0.8$ ← Covering t in the formula triangle finds that time = distance ÷ speed. So dividing the distance from Liverpool to Manchester by the average speed from Liverpool to Manchester gives the time it took in hours

$75 \div 60 = 1.25$ ← There are 60 minutes in an hour so dividing the 75 minutes by 60 converts the time taken from Manchester to Sheffield into hours

$0.8 + 1.25$ ← Adding the times taken in hours from Liverpool to Manchester and from Manchester to Sheffield works out the total time from Liverpool to Sheffield in hours

$117 \div 2.05$ ← Covering s in the formula triangle finds that speed = distance ÷ time. So dividing the distance from Liverpool to Sheffield by the time taken from Liverpool to Sheffield in hours gives the average speed in kilometres per hour

..... 57.1 km/h
(4)

Janie drove from Barnsley to York.

Janie's average speed from Barnsley to Leeds was 80 km/h.
Her average speed from Leeds to York was 60 km/h.

Janie says that the average speed from Barnsley to York can be found by working out the mean of 80 km/h and 60 km/h.

(b) If Janie is correct, what does this tell you about the two parts of Janie's journey?

Both parts must have taken the same amount of time

..... If Janie went 80 km/h for a longer duration than 60 km/h, the average would be closer to 80 km/h than to 60 km/h. The mean is exactly halfway between the two speeds

(1)

(Total for Question 20 is 5 marks)

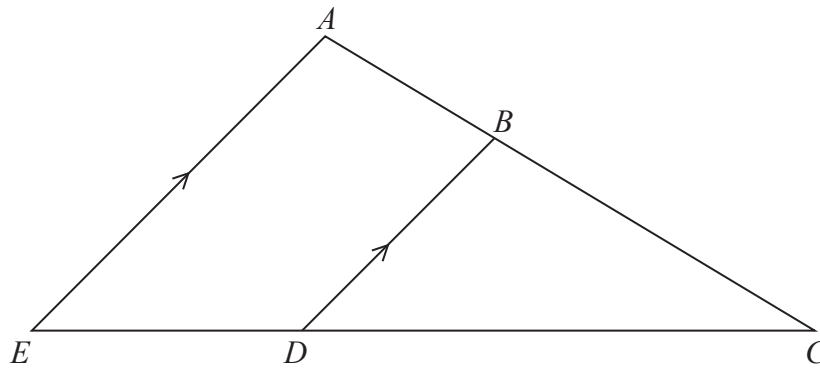

ABC and EDC are straight lines.

EA is parallel to DB .

$EC = 8.1$ cm.

$DC = 5.4$ cm.

$DB = 2.6$ cm.

Triangle ACE is similar to triangle BCD as all the angles in both triangles are the same. So both triangles are the same shape but triangle ACE is a bigger version of triangle BCD

(a) Work out the length of AE .

$8.1 \div 5.4$ ← EC is the bigger version of side DC. So dividing EC by DC works out that the scale factor is 1.5

2.6×1.5 ← AE is the bigger version of DB. So multiplying DB by the scale factor works out AE

..... 3.9 cm
(2)

$AC = 6.15$ cm.

(b) Work out the length of AB .

$6.15 \div 1.5$ ← BC is the smaller version of AC. So dividing AC by the scale factor works out BC

$6.15 - 4.1$ ← Subtracting BC from AC leaves AB

..... 2.05 cm
(2)

(Total for Question 21 is 4 marks)

22 Anil wants to invest £25 000 for 3 years in a bank.

Personal Bank
Compound Interest
2% for each year

Secure Bank
Compound Interest
4.3% for the first year
0.9% for each extra year

Which bank will give Anil the most interest at the end of 3 years?
You must show all your working.

$$\frac{100 + 2}{100} = 1.02$$

$$\frac{100 + 4.3}{100} = 1.043$$

$$\frac{100 + 0.9}{100} = 1.009$$

Converting the percentage interest into decimal multipliers by adding the percentage interest to 100% then putting it over 100

$$25000 \times 1.02^3 = 26530.20$$

Multiplying the £25000 by 1.02 increases it by 2%. Raising the 1.02 to the power of 3 as it needs to be increased by 2% 3 times. So the amount in the account at the end of 3 years with Personal Bank is £26530.20

$$25000 \times 1.043 \times 1.009^2 = 26546.46$$

Multiplying the £25000 by 1.043 increases it by 4.3%. Then multiplying this by 1.009 increases it by 0.9%. Raising the 1.009 to the power of 2 as it needs to be increased by 0.9% 2 times. So the amount in the account at the end of 3 years with Secure Bank is £26546.46

Secure Bank

£26546.46 is more than £26530.20, so as they started with the same £25000, Secure Bank will give the most interest

(Total for Question 22 is 3 marks)

23 A number, n , is rounded to 2 decimal places.
The result is 4.76

Using inequalities, write down the error interval for n .

$$4.76 \pm \frac{0.01}{2}$$

Adding and subtracting half of the resolution from the 4.76 gives the upper and lower bound. 0.01 is the resolution as this is what the 2nd decimal place goes up in

If it went lower than 4.755 it would round down to 4.75.
If it went as high as 4.765 it would round up to 4.77

$$4.755 \leq n < 4.765$$

(Total for Question 23 is 2 marks)

24 Solve $x^2 + 5x - 24 = 0$

$(x + 8)(x - 3) = 0$ ← Two numbers which multiply to the -24 and add to the 5 are 8 and -3. Putting these in brackets with x factorises the left side

Either $x + 8 = 0$ (so $x = -8$) or $x - 3 = 0$ (so $x = 3$) → $x = -8$
 $x = 3$

(Total for Question 24 is 3 marks)

25 Here are the first six terms of an arithmetic sequence.

3 8 13 18 23 28

(a) Find an expression, in terms of n , for the n th term of this sequence.

It increases by 5 between each term so must involve $5n$. Going backward in the sequence finds that the 0th term (the one before the 1st term) would be -2 . So the n th term is $5n - 2$

$5n - 2$

(2)

The n th term of a different sequence is $3n^2$
Nathan says that the 4th term of this sequence is 144

(b) Is Nathan right?
Show how you get your answer.

$3(4)^2 = 48$ ← $n = 4$ for the 4th term. Substituting this in the n th term gives 48 as the 4th term

No ← 48 is the 4th term, not 144

(1)

(Total for Question 25 is 3 marks)

TOTAL FOR PAPER IS 80 MARKS