

Please write clearly in block capitals.

Centre number

--	--	--	--	--

Candidate number

--	--	--	--

Surname _____

Forename(s) _____

Candidate signature _____

GCSE MATHEMATICS

H

Higher Tier Paper 1 Non-Calculator

Thursday 2 November 2017 Morning Time allowed: 1 hour 30 minutes

Materials

For this paper you must have:

- mathematical instruments

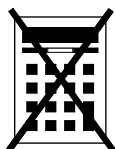

You must **not** use a calculator.

For Examiner's Use	
Pages	Mark
2–3	
4–5	
6–7	
8–9	
10–11	
12–13	
14–15	
16–17	
18–19	
20–21	
22–23	
24–25	
26–27	
TOTAL	

Instructions

- Use black ink or black ball-point pen. Draw diagrams in pencil.
- Answer **all** questions.
- You must answer the questions in the spaces provided. Do not write outside the box around each page or on blank pages.
- Do all rough work in this book. Cross through any work you do not want to be marked.

Information

- The marks for questions are shown in brackets.
- The maximum mark for this paper is 80.
- You may ask for more answer paper, graph paper and tracing paper. These must be tagged securely to this answer book.

Advice

- In all calculations, show clearly how you work out your answer.



Please note that these worked solutions have neither been provided nor approved by AQA and may not necessarily constitute the only possible solutions. Please refer to the original mark schemes for full guidance.

Any writing in blue indicates what must be written in order to answer the questions and get the marks. The worked solutions have been designed to show the smallest amount of work which needs to be done to answer the question.

Anything written in green in a cloud doesn't have to be written in the exam.

Anything written in orange in a rectangle doesn't have to be written in the exam and is there to show what should be put into a calculator or measured using a ruler or protractor.

If you find any mistakes or have any requests or suggestions, please send an email to curtis@cgmaths.co.uk

Using column subtraction, making sure that all the digits are in the right places values. Adding a 0 onto the end of 1.3 does not change its value

Answer **all** questions in the spaces provided

- 1 Work out $\sqrt{2^6 + 6^2}$
Circle your answer.

[1 mark]

10 14 50 100

$2^6 = 2 \times 2 \times 2 \times 2 \times 2 \times 2$. Keep doubling works this out as 2, 4, 8, 16, 32, 64. $6^2 = 6 \times 6 = 36$. $64 + 36 = 100$. $\sqrt{100} = 10$

- 2 What is 800 million in standard form?
Circle your answer.

[1 mark]

800×10^6 8×10^8 8×10^9 0.8×10^{10}

$800 = 8 \times 10^2$. A million = 10^6 . $8 \times 10^2 \times 10^6 = 8 \times 10^8$

- 3 Circle the expression that is equivalent to $(4a^5)^2$

[1 mark]

$16a^{10}$ $16a^7$ $8a^{10}$ $8a^7$

$4^2 = 16$. $(a^5)^2 = a^{10}$



4 $y = \frac{10}{x}$

If the value of x doubles, what happens to the value of y ?

Circle your answer.

[1 mark]

$\div 2$

$\times 2$

$\div 5$

$\times 5$

Doubling the denominator means dividing by twice the amount, which is basically dividing by 2

5 (a) Factorise $x^2 - 100$

[1 mark]

Factorised using difference of two squares. $A^2 - B^2 = (A + B)(A - B)$. $A^2 = x^2$, so $A = x$. $B^2 = 100$, so $B = 10$

Answer $(x + 10)(x - 10)$

5 (b) Solve $7x + 6 > 1 + 2x$

[2 marks]

$5x + 6 > 1$ ← Subtracting $2x$ from both sides to get the x terms on the same side

$5x > -5$ ← Subtracting 6 from both sides to get the x term on its own

Answer $x > -1$

Dividing both sides by 5 gets x on its own



6 Work out the value of $(\sqrt{3})^2 \times (\sqrt{2})^2$

[2 marks]

$$3 \times 2$$

The square and the square root cancel out as they are opposites

Answer 6

7 Here is a quarter circle of radius 6 cm

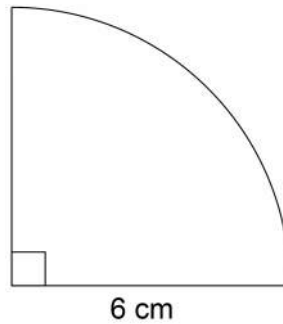

Not drawn
accurately

Work out the area of the quarter circle.

Give your answer in terms of π .

[2 marks]

$$\frac{1}{4} \pi \times 6^2$$

Area of circle = $\pi \times \text{radius}^2$. Doing $1/4$ of this as it is a quarter circle. Of means to multiply

Answer 9π cm^2

$6^2 = 36$. Multiplication can be done in any order so $1/4 \times 36 = 9$.
 π is left in the answer as it needs to be in terms of π



- 8 Three **whole** numbers are each rounded to the nearest 10
The sum of the rounded numbers is 70

Work out the **maximum** possible sum for the original three numbers.

[2 marks]

$$30 + 20 + 20$$

These could be the three numbers when rounded to the nearest 10 as they add to 70

$$34 + 24 + 24$$

These are the highest the three whole numbers could be and still round down. They add to 82

It doesn't matter which values were picked for the three numbers when rounded to the nearest 10 as 4 will be added to each of them when working out the highest the three whole numbers could be and still round down. The result will always be 82

Answer 82

- 9 Circle the expression for the range of n consecutive integers.

[1 mark]

$$\frac{n+1}{2}$$

$$n-1$$

$$n$$

$$n+1$$

Take for example the consecutive integers 4, 5, 6, 7. There are 4 of them so n is 4. The range is largest - smallest = $7 - 4 = 3$. Only $n - 1$ works as $4 - 1 = 3$

Turn over for the next question



10 (b) This diagram shows the same trapezium.

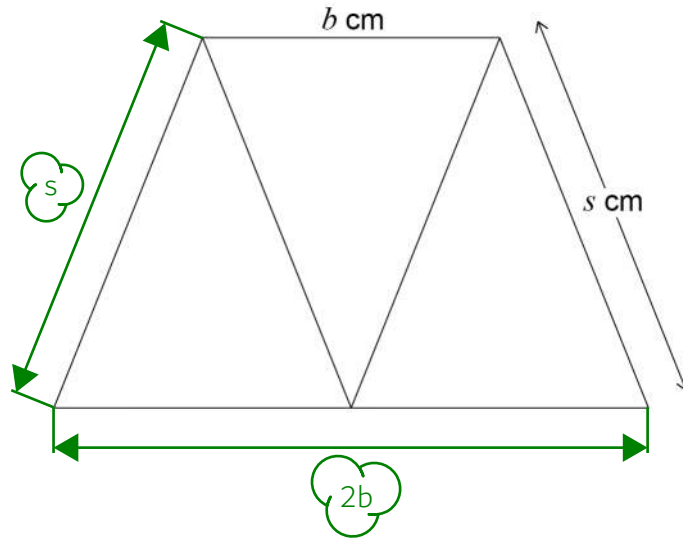

$$b : s = 2 : 3$$

Work out an expression, in terms of b , for the perimeter of the trapezium.

[2 marks]

s is $\frac{3}{2} \times b$ as 3 is $\frac{3}{2} \times 2$. Adding all of the outside sides together expresses the perimeter. There is no need to simplify the expression

Answer $b + 2b + \frac{3}{2}b + \frac{3}{2}b$ cm

Turn over for the next question



- 11 The four candidates in an election were A, B, C and D.
The pie chart shows the proportion of votes for each candidate.

Proportion of votes

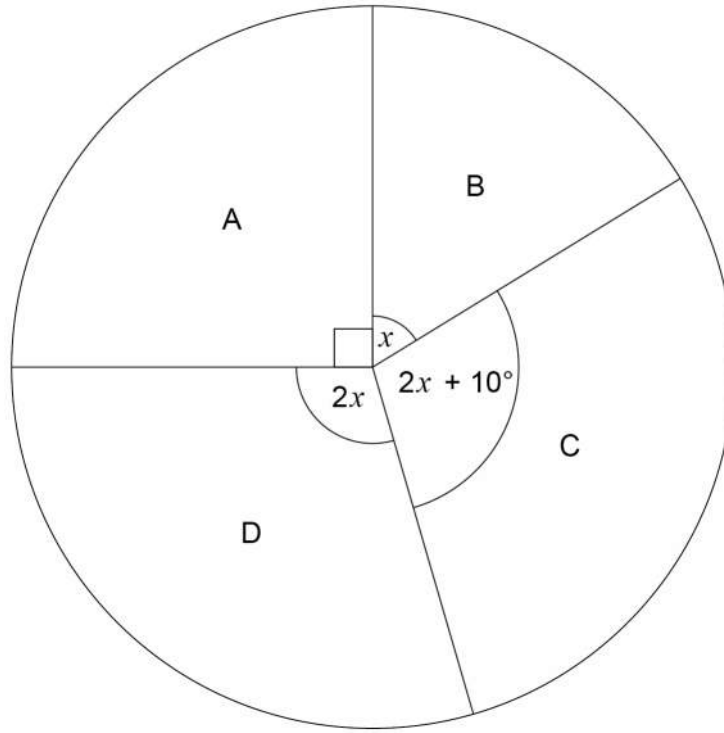
Not drawn
accurately

Work out the probability that a person who voted, chosen at random, voted for C.

[4 marks]

$$90 + x + 2x + 10 + 2x \leftarrow \text{Adding all the angles to express the total number of degrees}$$

$$5x + 100 = 360 \leftarrow \text{Simplifying the expression by collecting like terms. Setting it equal to 360 as the total number of degrees in a pie chart is 360}$$

$$5x = 260 \leftarrow \text{Subtracting 100 from both sides to get the x term on its own}$$

$$\begin{array}{r} 052 \\ 5 \overline{)260} \end{array} \leftarrow \text{Dividing both sides by 5 finds that } x = 52$$

$$\begin{array}{r} 52 \\ \times 2 \\ \hline 104 + 10 \end{array} \leftarrow \text{Substituting 52 for x in } 2x + 10 \text{ works out that the angle for C is 114 degrees}$$

Answer _____

$$\frac{114}{360}$$

114 out of the 360 degrees represent C



12

Use approximations to 1 significant figure to estimate the value of

$$\frac{0.526 \times 39.6^2}{\sqrt{97.65}}$$

You **must** show your working.**[3 marks]**

$$40^2$$

39.6 to 1 significant figure is 40. $4^2 = 16$ so $40^2 = 1600$

$$0.5 \times 1600$$

0.526 to 1 significant figure is 0.5. $0.5 = 1/2$ so multiplying by 0.5 is basically dividing by 2. $1600/2 = 800$

$$\frac{800}{10}$$

97.65 to 1 significant figure is 100. $100 = 10$.
Dividing by 10 removes a zero from the end

Answer 80

Turn over for the next question

Turn over ►



13 $x : y = 7 : 4$

$x + y = 88$

Work out the value of $x - y$

[3 marks]

$7 + 4$

There are 11 parts in total which represent the total of 88

$88 \div 11$

Dividing the 88 by the 11 parts works out that 1 part of the ratio is worth 8

8×7

Multiplying the value of 1 part by 7 works out that x is 56

8×4

Multiplying the value of 1 part by 4 works out that y is 32

$$\begin{array}{r} 56 \\ - 32 \\ \hline 24 \end{array}$$

Subtracting the value of y from the value of x finds that $x - y = 24$

Answer _____

24



- 14 Two congruent regular polygons are joined together.

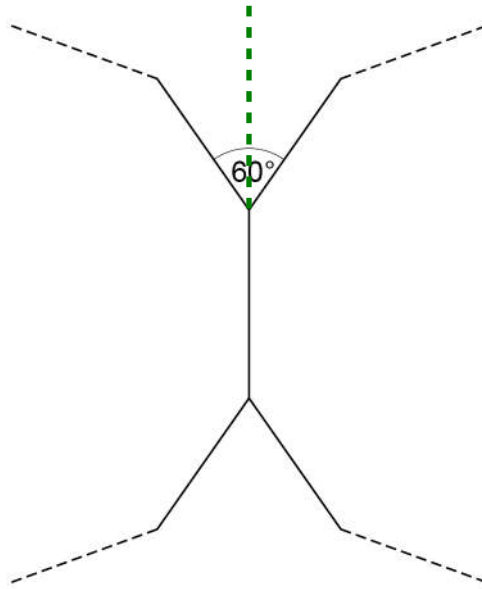

Not drawn
accurately

Work out the number of sides on each polygon.

[3 marks]

$$60 \div 2$$

The line drawn above divides the angle into 2 and creates exterior angles of both of the polygons

$$30 \overline{) 360} \begin{array}{r} 012 \\ \underline{360} \\ 0 \end{array}$$

The sum of the exterior angles of a polygon is 360° . As they are regular, all of the exterior angles are the same. So dividing 360° by the exterior angle of 30° works out how many exterior angles there are. There are as many sides as there are exterior angles

Answer 12

Turn over for the next question



15

Meal Deal

Choose one sandwich, one drink and one snack

There are

7 different sandwiches

5 different drinks

and

3 different snacks.

15 (a) How many different Meal Deal combinations are there?

[2 marks]

$$\begin{array}{r} 35 \\ \times 3 \\ \hline 105 \end{array}$$

The product rule for counting can be used. Multiplying the number of possible outcomes of each individual event works out the total number of possible outcomes. So $7 \times 5 \times 3$ works out the number of combinations. $7 \times 5 = 35$ then multiplying this by 3

Answer 105

15 (b) Two of the sandwiches have cheese in them.

Three of the drinks are fizzy.

Eva picks a Meal Deal at random.

Work out the probability that the sandwich has cheese in it **and** the drink is fizzy.

Give your answer as a fraction.

[2 marks]

$$2 \times 3 \times 3$$

Using the product rule for counting again to work out how many combinations there are where the sandwich has cheese in it and the drink is fizzy. There are also still 3 different snacks

Answer $\frac{18}{105}$

18 out of the 105 possible combinations are where the sandwich has cheese in it and the drink is fizzy



16

Water is poured into a tank.

The graph shows the number of litres of water in the tank.

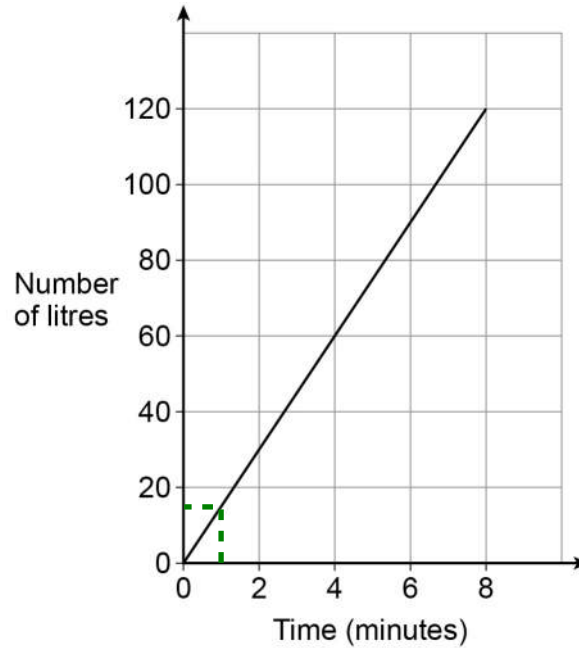

How much water is poured into the tank each minute?

Circle your answer.

[1 mark]

1.5 litres

15 litres

30 litres

120 litres

Reading up from 1 minute to the line then across. The answer can only be 15 litres as the others aren't close

Turn over for the next question

Turn over ►



17 A and B are **similar** solids.

Solid	length (cm)
A	l
B	$2l$

Alex says,

“The volume of B is double the volume of A
because the length of B is double the length of A.”

Is he correct?

Tick a box.

Yes

No

Give a reason for your answer.

[1 mark]

Volume scale factor is 2^3

The unit of length is cm and the unit of volume is cm^3 . So multiplying the length by 2 multiplies the volume by 2^3

18 Circle the **two** roots of $(2x + 3)(5x - 2) = 0$

[1 mark]

$$\left(-\frac{3}{2}\right)$$

$$-\frac{2}{5}$$

$$\left(\frac{2}{5}\right)$$

$$\frac{3}{2}$$

Either $2x + 3 = 0$ or $5x - 2 = 0$. Rearranging the first equation by subtracting 3 from both sides then dividing both sides by 2 works out that $x = -3/2$. Rearranging the second equation by adding 2 to both sides then dividing both sides by 5 works out that $x = 2/5$



- 19 The diagram shows a triangle and a trapezium.

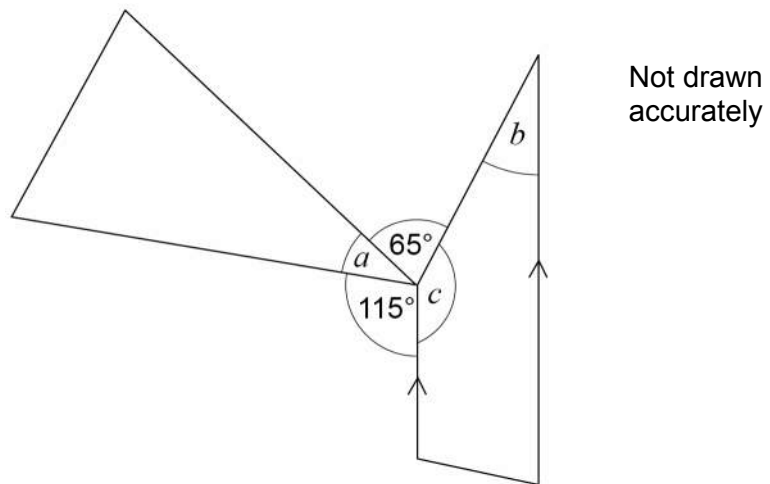

Prove that $a = b$

[3 marks]

$c = 180 - b$ as co-interior angles add up to 180

b and c are co-interior angles

$a + 65 + 115 + 180 - b = 360$ as angles around a point add up to 360

Substituted c for $180 - b$

$a - b = 0$

$65 + 115 + 180 = 360$. Subtracting 360 from both sides of the equation above give this

$a = b$

Adding b to both sides

Turn over for the next question



20

In one month, the number of hours of exercise taken by 10 people are

4 7 2 8 6 5 1 82 3 9

Which is the appropriate average to use in this situation?

Tick a box.

Mean

Median

Mode

Give one reason for each of the other two averages as to why they are **not** appropriate.

[2 marks]

Reason 1 82 is an outlier

This will increase the mean a lot and the average will not represent the data very well

Reason 2 There is no mode

All of the numbers only appear once so none of them are the most frequent



21

A, B and C are points on the axes as shown.

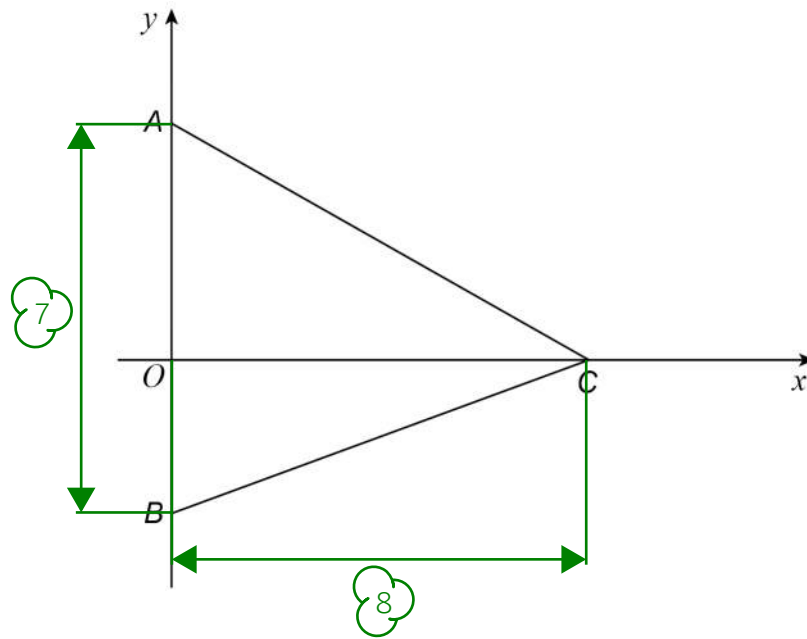
Not drawn
accurately

The area of triangle ABC is 28 square units.

Work out possible coordinates for A, B and C.

[2 marks]

$$\frac{1}{2}bh = 28$$

Area of triangle = $\frac{1}{2} \times \text{base} \times \text{height}$

$$\begin{array}{r} 28 \\ \times 2 \\ \hline 56 \end{array}$$

Multiplying both sides by 2 eliminates the $\frac{1}{2}$ and works out the base \times height

The base (length AB) could be 7 and the height (length OC) could be 8 as $7 \times 8 = 56$. The x-coordinate of A and B must be 0 as they are on the y-axis. The y-coordinate of A must be positive and the y-coordinate of B must be negative. The y-coordinate of C must be 0 as it is on the x-axis and the x-coordinate must be positive

A (0 , 5) B (0 , -2) C (8 , 0)

Turn over for the next question**Turn over ►**

- 22 Here is some information about the miles per gallon of 60 cars.

Miles per gallon, x	Frequency	Cumulative frequency
$40 < x \leq 50$	6	6
$50 < x \leq 60$	16	22
$60 < x \leq 70$	28	50
$70 < x \leq 80$	10	60

Adding the frequency up as they go works out the cumulative frequency

- 22 (a) Draw a cumulative frequency graph.

[3 marks]

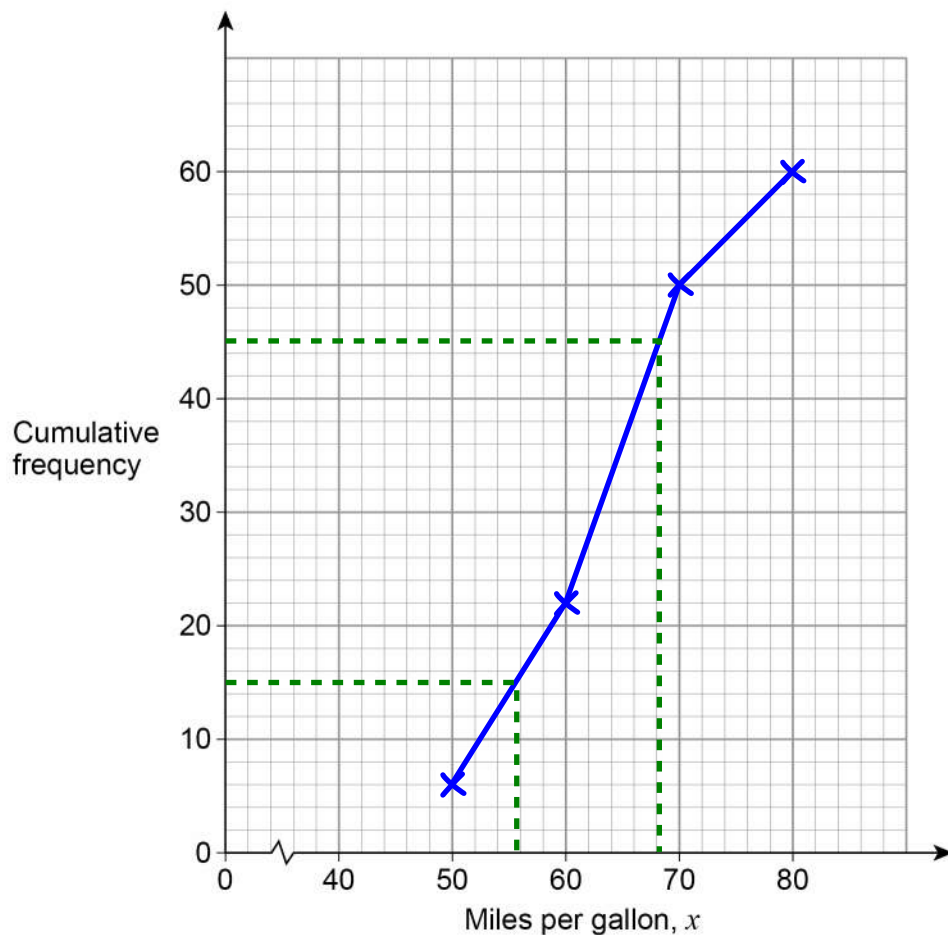

The cumulative frequencies are plotted at the end point of each category as it is reached by the end of the category. Joining up the points with a series of straight lines (a curve may be used but it is harder) completes the graph



22 (b) Use the graph to work out the interquartile range.

[2 marks]

$$\begin{array}{r} 68 \\ -56 \\ \hline 12 \end{array}$$

Interquartile range = upper quartile - lower quartile. The lower quartile is $\frac{1}{4}$ of the way through the data and this is roughly the 15th frequency as $60/4 = 15$. Reading across from 15 to the line then down works out an estimate of the lower quartile. The upper quartile is $\frac{3}{4}$ of the way through the data and this is roughly the 45th frequency as $15 \times 3 = 45$. Reading across from 45 to the line then down works out an estimate of the upper quartile

Answer 12 miles per gallon

23 The equation of a curve is $y = (x + 3)^2 + 5$

Circle the coordinates of the turning point.

[1 mark]

(5, 3)

(5, -3)

(3, 5)

(-3, 5)

The turning point occurs when $x + 3 = 0$ as 0^2 is the minimum a squared number can be. $x = -3$ and $y = 5$ when this is the case

Turn over for the next question



24

Here is a cyclic quadrilateral.

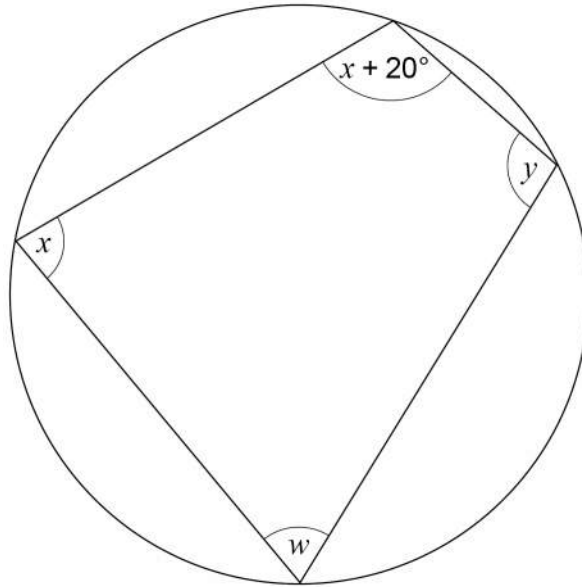
Not drawn
accurately

$$x : y = 5 : 7$$

Work out the size of angle w .**[4 marks]**

$$12 \overline{) 180} \begin{array}{r} 015 \\ \underline{120} \\ 60 \\ \underline{60} \\ 0 \end{array}$$

x and y are opposite angles in a cyclic quadrilateral so they add up to 180 degrees. This total is represented by a total of 12 parts in the ratio as $5 + 7 = 12$. Dividing the 180 degrees by the 12 parts works out that the value of 1 part of the ratio is 15 degrees

$$\begin{array}{r} 15 \\ \times 5 \\ \hline 75 + 20 \\ \hline \end{array}$$

x is represented by 5 parts in the ratio so multiplying the value of 1 part by 5 works out that x is 75. Adding 20 to this works out the value of the $x + 20$ angle

$$\begin{array}{r} 180 \\ - 95 \\ \hline 85 \end{array}$$

w and the $x + 20$ angle are opposite angles in a cyclic quadrilateral so they add up to 180 degrees. Subtracting the value of the $x + 20$ angle from 180 degrees leaves the value of w

Answer 85 degrees

25

15 machines work at the same rate.

Together, the 15 machines can complete an order in 8 hours.

3 of the machines break down after working for 6 hours.

The other machines carry on working until the order is complete.

In total, how many hours does **each** of the other machines work?

[3 marks]

$$\begin{array}{r} 15 \\ \times 8 \\ \hline 120 \end{array} - \begin{array}{r} 15 \\ \times 6 \\ \hline 90 \end{array}$$

15 machines working for 8 hours do a total of 120 hours worth of work. 15 machines working for 6 hours do a total of 90 hours worth of work. Subtracting the 90 hours from the 120 hours works out that there are another 30 hours worth of work to be done once the 3 machines have broken down

$$12 \overline{) 30.0} + 6$$

Dividing the 30 hours worth of work by the 12 machines doing the work ($15 - 3 = 12$ after the 3 machines have broken down) works out how long it will take. Adding the 6 hours already done works out the total number of hours the other machines work

Answer 8.5 hours

Turn over for the next question



26 (a) $0.\dot{7} = \frac{7}{9}$

Use this fact to show that $0.0\dot{7} = \frac{7}{90}$

[1 mark]

$$0.\dot{7} \div 10 = 0.0\dot{7}$$

$$\frac{7}{9} \div 10 = \frac{7}{90}$$

Dividing by 10 moves the decimal point once to the left

$$7/9 \div 10/1 = 7/9 \times 1/10 = 7/90$$

26 (b) Using part (a) or otherwise, convert $0.2\dot{7}$ to a fraction.

Give your answer in its simplest form.

[3 marks]

$$\frac{2}{10} + \frac{7}{90}$$

0.2 is worth 2/10. Adding this to 0.07 gives 0.27

$$\frac{18}{90} + \frac{7}{90}$$

Converting 2/10 into 18/90 so both of the denominators are the same by multiplying the numerator and denominator by 9

$$\frac{25}{90}$$

18 + 7 = 25. The denominator stays the same

$$5 \overline{) 25} \begin{array}{r} 5 \\ \underline{25} \\ 0 \end{array}$$

Answer _____

$$\frac{5}{18}$$

Dividing both the numerator and denominator by 5 simplifies the fraction. 5 and 18 cannot be divided by the same amount any more to get whole numbers



27

There are 11 pens in a box.

8 are black and 3 are red.

Two pens are taken out at random **without** replacement.

Work out the probability that the two pens are the **same** colour.

[4 marks]

$$\frac{8}{11} \times \frac{7}{10} + \frac{3}{11} \times \frac{2}{10}$$

Black AND black OR red AND red. AND means to multiply the probabilities. OR means to add the probabilities. There is 1 fewer pen in total after the first is picked so the denominators go down to 10 for the second pick. There is 1 fewer black pen once the first black is picked so the number of black pens goes down to 7 for the second black. There is 1 fewer red pen once the first red is picked so the number of red pens goes down to 2 for the second red

$$\frac{56}{110} + \frac{6}{110}$$

To multiply fractions: multiply the numerators and multiply the denominators

Answer _____

$$\frac{62}{110}$$

Adding the numerators as the denominators are already the same

8

Turn over ►



28 A, B and C are points on the circle $x^2 + y^2 = 36$ as shown.

A is on the y -axis.

B is on the x -axis.

M is the midpoint of AB .

COM is a straight line.

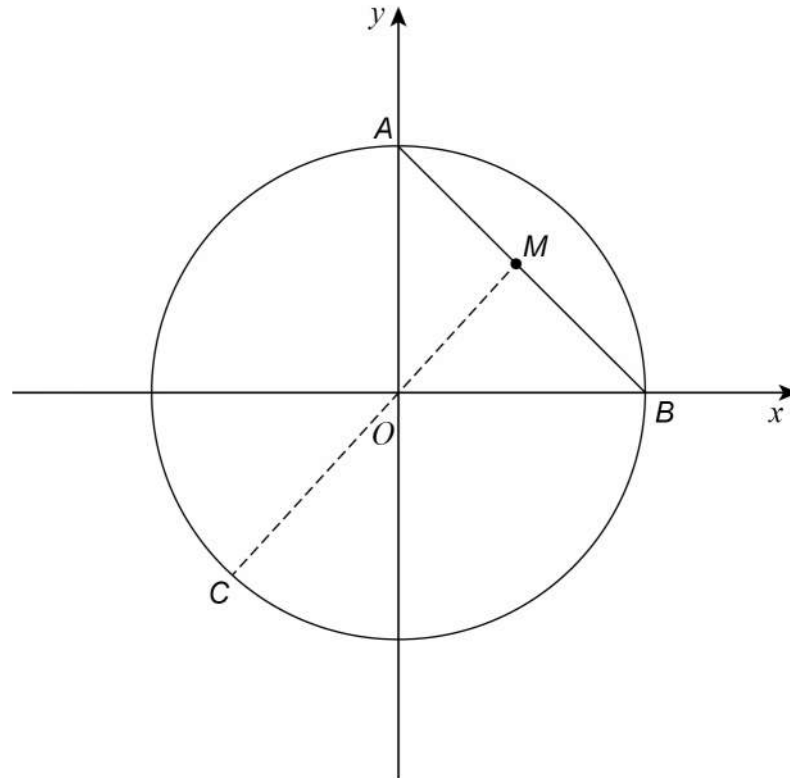

28 (a) Show that the coordinates of A are $(0, 6)$

[1 mark]

$$0^2 + 6^2 = 36$$

Substituting the x and y -coordinate of point A into the equation of the circle to show that the coordinates satisfy the equation shows that A is on the circle and the x -coordinate is 0 so it is on the y -axis

28 (b) Work out the coordinates of B .

[1 mark]

The y coordinate must be 0 as it is on the x -axis. Substituting 0 for y in the equation gives $x^2 + 0^2 = 36$ so $x^2 = 36$. Square rooting both sides gives that $x = 6$. The negative square root is ignored as the x -coordinate of B must be positive

Answer (6 , 0)



28 (c) Show that the equation of the straight line passing through C, O and M is $y = x$

[2 marks]

$$\left(\frac{0+6}{2}, \frac{6+0}{2}\right) = (3, 3)$$

M is the midpoint of AB so working out the mean of the x-coordinates and y-coordinates of A and B works out that the coordinates of M are (3, 3)

$$\frac{3-0}{3-0} = 1$$

This shows that the gradient of OM is 1. Gradient = (change in y)/(change in x). The coordinates of O are (0, 0). Change in y = 3 - 0 and change in x = 3 - 0

The general equation of a straight line is $y = mx + c$, where m is the gradient and c is the y intercept. The gradient is 1 and the y intercept is 0 so $y = 1x + 0$, which is $y = x$

28 (d) Work out the coordinates of C.

Give your answers in surd form.

[3 marks]

$$2x^2 = 36$$

The lines $x^2 + y^2 = 36$ and $y = x$ meet at point C. So doing simultaneous equations works out the coordinates of the intersection at C. Substituting x for y in $x^2 + y^2 = 36$ gives $x^2 + x^2 = 36$

$$x^2 = 18$$

Dividing both sides by 2 to get the x^2 on its own

$$x = \pm\sqrt{18}$$

Doing the positive and negative square root of both sides undoes the power of 2

$$\text{Answer (} \underline{-\sqrt{18}} \text{ , } \underline{-\sqrt{18}} \text{)}$$

The x-coordinate must be negative as it is on the left of the y-axis. So the positive solution is ignored. As $y = x$, the y-coordinate is the same as the x-coordinate



29 Here is a sketch of $y = \sin x^\circ$ for $-360 \leq x \leq 360$

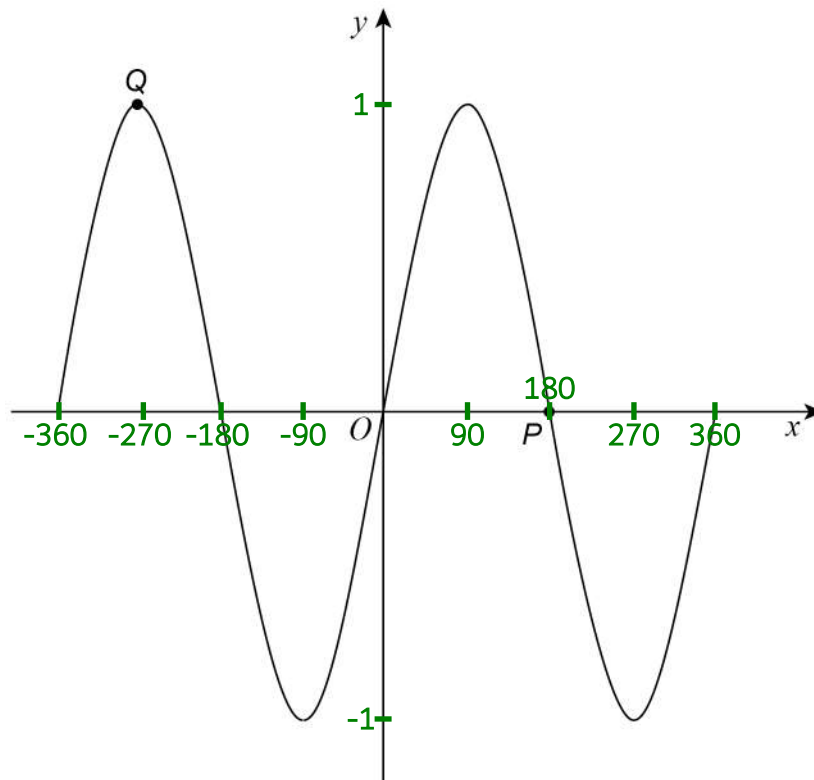

29 (a) Write down the coordinates of P .

[1 mark]

Answer (180 , 0)

29 (b) Write down the coordinates of Q .

[1 mark]

Answer (-270 , 1)



