

Please check the examination details below before entering your candidate information

Candidate surname

Other names

Centre Number

Candidate Number

--	--	--	--	--

--	--	--	--

Pearson Edexcel Level 1/Level 2 GCSE (9–1)

Time 1 hour 30 minutes

Paper
reference

1MA1/3F

Mathematics PAPER 3 (Calculator) Foundation Tier

You must have: Ruler graduated in centimetres and millimetres, protractor, pair of compasses, pen, HB pencil, eraser, calculator. Tracing paper may be used.

Total Marks

Instructions

- Use **black** ink or ball-point pen.
- **Fill in the boxes** at the top of this page with your name, centre number and candidate number.
- Answer **all** questions.
- Answer the questions in the spaces provided – *there may be more space than you need.*
- You must **show all your working**.
- Diagrams are **NOT** accurately drawn, unless otherwise indicated.
- **Calculators may be used.**
- If your calculator does not have a π button, take the value of π to be 3.142 unless the question instructs otherwise.



Information

- The total mark for this paper is 80
- The marks for **each** question are shown in brackets – *use this as a guide as to how much time to spend on each question.*

Advice

- Read each question carefully before you start to answer it.
- Try to answer every question.
- Check your answers if you have time at the end.

Turn over ►

P64633A

©2021 Pearson Education Ltd.

E:1/1/1/1/1/1/1/1/1/1/

.CG Maths.
Worked Solutions

Pearson

Please note that these worked solutions have neither been provided nor approved by Pearson Education and may not necessarily constitute the only possible solutions. Please refer to the original mark schemes for full guidance.

Any writing in blue should be written in the exam.

Anything written in green in a rectangle doesn't have to be written in the exam.

If you find any mistakes or have any requests or suggestions, please send an email to curtis@cgmaths.co.uk

Answer ALL questions.

Write your answers in the spaces provided.

You must write down all the stages in your working.

- 1 Write 45% as a decimal.

Percentages are out of 100 so dividing by 100 converts it into a decimal. $45 \div 100 = 0.45$

..... 0.45

(Total for Question 1 is 1 mark)

2 Write down two factors of 35

$1 \times 35 = 35$ so 1 and 35 are both factors of 35

..... 1, 35

(Total for Question 2 is 1 mark)

3 What is the time 2 hours 40 minutes after 8.05 am?

Entering the times as sexagesimals on the calculator.
 $8^{\circ}05^{\circ} + 2^{\circ}40^{\circ} = 10^{\circ}45'0''$, which can be read as 10.45am

..... 10.45

..... am

(Total for Question 3 is 1 mark)

4 Work out $\frac{1}{6}$ of 66

Of means to multiply. $1/6 \times 66 = 11$

..... 11

(Total for Question 4 is 1 mark)

2

.CG Maths.

DO NOT WRITE IN THIS AREA

DO NOT WRITE IN THIS AREA

DO NOT WRITE IN THIS AREA

DO NOT WRITE IN THIS AREA

DO NOT WRITE IN THIS AREA

DO NOT WRITE IN THIS AREA

5 AB is a straight line.

Mark with a cross (X) the midpoint of AB .

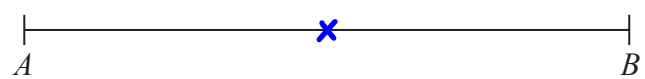

(Total for Question 5 is 1 mark)

6 (a) Simplify $a \times b \times 4$

Writing the numbers and letters next to each other means that they are multiplied

$$\begin{array}{r} 4ab \\ \hline \end{array}$$

(1)

(b) Simplify $4x + 3 - x + 5$

Collecting like terms. $4x - x = 3x$. $3 + 5 = 8$

$$\begin{array}{r} 3x+8 \\ \hline \end{array}$$

(2)

(Total for Question 6 is 3 marks)

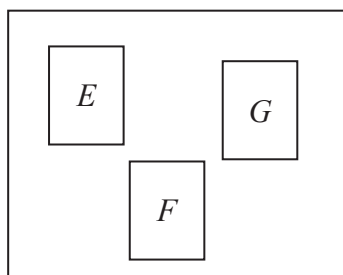
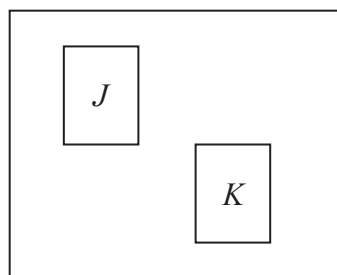

- 7 There are three cards in bag **A** and two cards in bag **B**.
There is a letter on each card.

Bag **A**Bag **B**

James takes a card from bag **A** and then a card from bag **B**.

List all the possible outcomes.

EJ, EK, GJ, GK, FJ, FK

Using systematic listing

(Total for Question 7 is 2 marks)

- 8 On Monday, Sandy pays for 2 plane tickets, 7 nights in a hotel and 2 theme park tickets.

	dollars
each plane ticket	600
each night in a hotel	120
each theme park ticket	250

Show that Sandy pays more than 2500 dollars on Monday.

$$2 \times 600 + 7 \times 120 + 2 \times 250 = 2540$$

Adding together all of the costs shows that it costs \$2540, which is more than \$2500

Cost of 2 theme park tickets

Cost of 7 nights in a hotel

Cost of 2 plane tickets

(Total for Question 8 is 3 marks)

DO NOT WRITE IN THIS AREA

DO NOT WRITE IN THIS AREA

DO NOT WRITE IN THIS AREA

- 9 Vadim has 56 clocks.
The clocks are only red, only blue or only black.

32 of the clocks are plastic.
5 of the 14 blue clocks are plastic.
8 of the 12 red clocks are **not** plastic.

Use this information to complete the two-way table.

	Red	Blue	Black	Total
Plastic	4	5	23	32
Not plastic	8	9	7	24
Total	12	14	30	56

(Total for Question 9 is 3 marks)

- 10 Corina has £300 to spend on books.
Each book costs £4.85

Work out the greatest number of books Corina can buy.

$$\frac{300}{4.85}$$

Dividing the amount of money she has by the cost of each book works out how many lots of the £4.85 go into the £300

The answer of 61.8... is rounded down as there cannot be a decimal number of books and she cannot afford 62 books

61

(Total for Question 10 is 3 marks)



11 (a) Write 196 minutes in hours and minutes.

Entering the time as a sexagesimal on the calculator. $0^{\circ}196^{\circ} = 3^{\circ}16'0''$, which can be read as 3 hours and 16 minutes

..... 3 hours 16 minutes
(2)

A train travels x miles in 2 hours.

(b) Write down an expression, in terms of x , for the average speed of the train.

The unit of miles per hour mean that the distance in miles needs to be divided by the time in hours

..... $\frac{x}{2}$ miles per hour
(1)

(Total for Question 11 is 3 marks)

DO NOT WRITE IN THIS AREA

DO NOT WRITE IN THIS AREA

DO NOT WRITE IN THIS AREA

12 The diagram shows two places on a map.

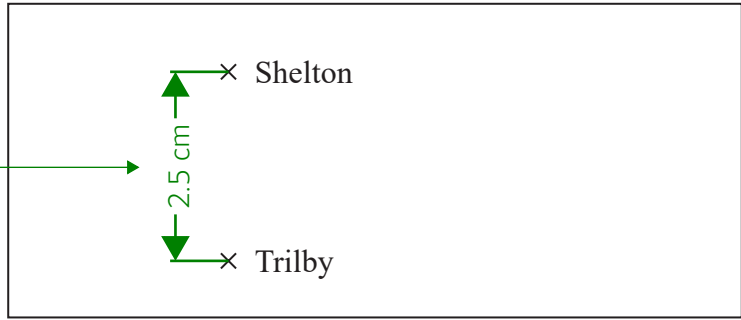

Measured the distance in centimetres using a ruler

Scale: 1 centimetre represents 20 kilometres

(a) What is the actual distance, in kilometres, from Shelton to Trilby?

2.5×20 ← There are 2.5 centimetres so the actual distance must be 2.5 lots of 20 kilometres

..... 50 kilometres
(2)

On a scale drawing, the scale is given as 1 : 1200

(b) How many metres does 5 centimetres represent on this drawing?

5×1200 ← 1200 is 1200 times greater than 1. So the actual length is 1200 times greater than 5 centimetres

$6000 \div 100$ ← There are 100 centimetres in a metre so dividing 6000 centimetres by 100 converts it into 60 metres

..... 60 metres
(2)

(Total for Question 12 is 4 marks)



13 In the Northern hemisphere the ratio of the area of land to the area of water is 2:3

(a) Work out what percentage of the area of the Northern hemisphere is land.

$$\frac{2}{5} \times 100 \leftarrow \begin{array}{l} 2 + 3 = 5 \text{ parts in total in the ratio. 2 out of these 5 parts are land.} \\ \text{Expressing this as a fraction. Multiplying by 100 converts it to a percentage} \end{array}$$

$$\dots\dots\dots 40 \dots\dots\dots \% \\ (2)$$

20% of the area of the Southern hemisphere is land.

(b) Work out the ratio of the area of land to the area of water in the Southern hemisphere.

$$100 - 20 \leftarrow \text{Subtracting the 20\% from 100\% finds that 80\% is water}$$

There is 20% land and 80% water. This can be written in a ratio and does not need to be simplified

$$\dots\dots\dots 20:80 \dots\dots\dots \\ (2)$$

(Total for Question 13 is 4 marks)



DO NOT WRITE IN THIS AREA

DO NOT WRITE IN THIS AREA

DO NOT WRITE IN THIS AREA

14 A stadium cost £600 million.

$\frac{13}{15}$ of this cost was for the building.

The rest of the cost was for the land.

Work out the cost of the land.

$\frac{13}{15} \times 600$ ← Of means to multiply. So 13/15 of the cost is 520 million

$600 - 520$ ← Subtracting the £520 million cost for the building from the £600 million cost finds that the rest of the cost is £80 million for the land

£.....80..... million

(Total for Question 14 is 3 marks)

15 Jenna measures all the angles around a point.

Her results are 23° , 145° , 23° and 69°

Explain why these results cannot be true.

They do not add to 360°

$23 + 145 + 23 + 69 = 260$. There are 360° around a point

(Total for Question 15 is 1 mark)



16 Here is a diagram showing triangle ABC and triangle ADE .

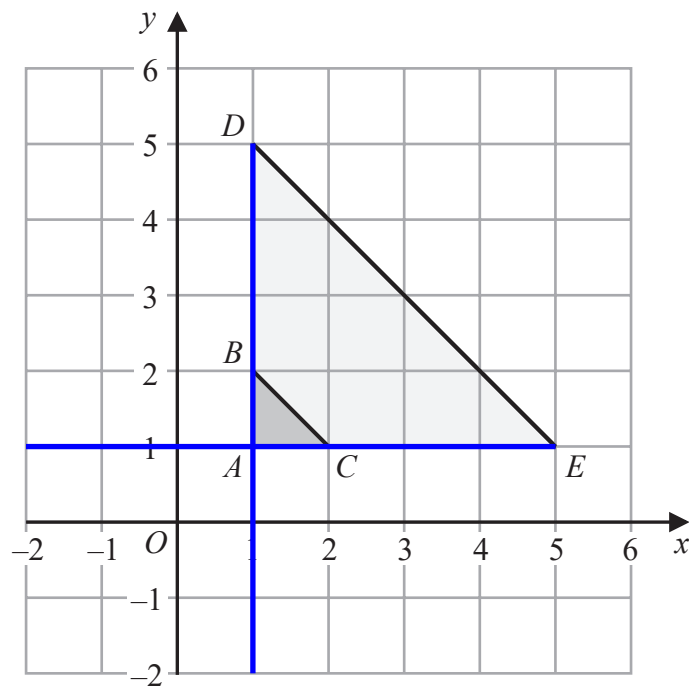

Describe fully the single transformation that maps triangle ABC onto triangle ADE .

Enlargement, scale factor 4, centre (1, 1)

It is an enlargement as it has changed size. The scale factor is 4 as all of the sides have been multiplied by 4. Drawing straight lines through the corners of both triangles and finding where they cross finds that the centre of enlargement is (1, 1)

(Total for Question 16 is 2 marks)

DO NOT WRITE IN THIS AREA

DO NOT WRITE IN THIS AREA

DO NOT WRITE IN THIS AREA

17 (a) Expand $y(y + 5)$

$$y^2 + 5y$$

(1)

(b) Factorise $4a - 6$

2 is the highest common factor of both terms so bringing this out as a factor by dividing both terms by it and leaving the result in a bracket

$$2(2a - 3)$$

(1)

(c) Solve $2(5x - 4) = 21$

$$5x - 4 = 10.5 \leftarrow \text{Dividing both sides by 2 eliminates the 2 on the left. The brackets are no longer needed}$$

$$5x = 14.5 \leftarrow \text{Adding 4 to both sides eliminates the -4 on the left and gets the x term on its own}$$

Dividing both sides by 5 eliminates the 5 on the left and gets x on its own

$$x = 2.9$$

(3)

(d) Simplify $4e^2f \times 5ef^3$

The multiplication can be done in any order. $4 \times 5 = 20$. $e^2 \times e = e^3$. $f \times f^3 = f^4$

$$20e^3f^4$$

(2)

(Total for Question 17 is 7 marks)

18 Change 1 m^2 into cm^2

$$1 \times 100^2 \leftarrow \text{There are 100cm in 1m. So multiplying by 100 converts metres to centimetres, however the unit is squared so it should be multiplied by } 100^2$$

Alternatively, consider a square which has an area of 1 m^2 . Converting the lengths into centimetres and finding out its area in cm^2 will be 100×100

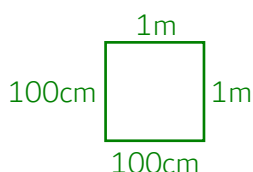

$$10000 \text{ cm}^2$$

(Total for Question 18 is 1 mark)

19 This diagram shows two squares.

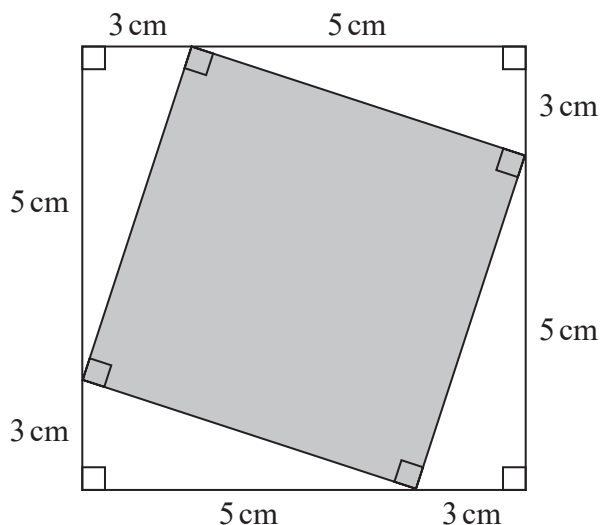

Work out the area of the square shown shaded in the diagram.

$3 + 5$ ← Adding the 3 cm and 5 cm finds that the side length of the outside square is 8 cm

$8^2 = 64$ ← Area of square = length². So the area of the outside square is 64 cm²

$0.5 \times 3 \times 5$ ← Area of triangle = $\frac{1}{2} \times \text{base} \times \text{height}$. So the area of one of the white triangle is 7.5 cm²

7.5×4 ← Multiplying the area of one of the white triangles by 4 finds that the area of all 4 white triangles is 30 cm²

$64 - 30$ ← Subtracting the area of the 4 white triangles from the area of the outside square finds that the area of the shaded square is 34 cm²

..... 34 cm²

(Total for Question 19 is 4 marks)

20 Here are the heights, in centimetres, of 15 plants.

15 20 25 33 17 22 25 18
22 19 32 35 24 28 19

Draw a stem and leaf diagram for these heights.

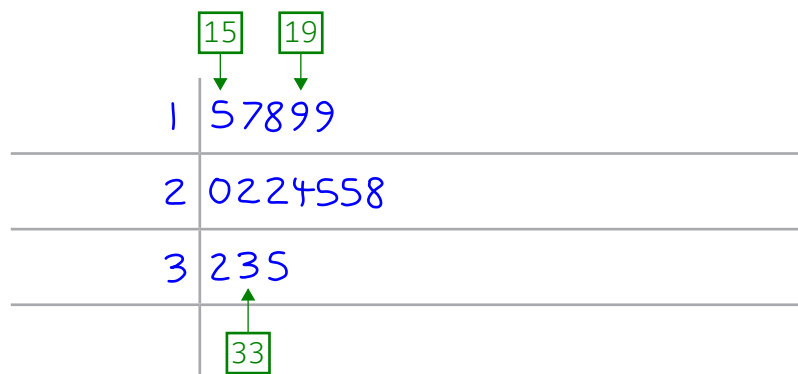

(Total for Question 20 is 3 marks)

- 21 The scatter graph shows information about the volume of traffic and the carbon monoxide level at a point on a road each day for 22 days.

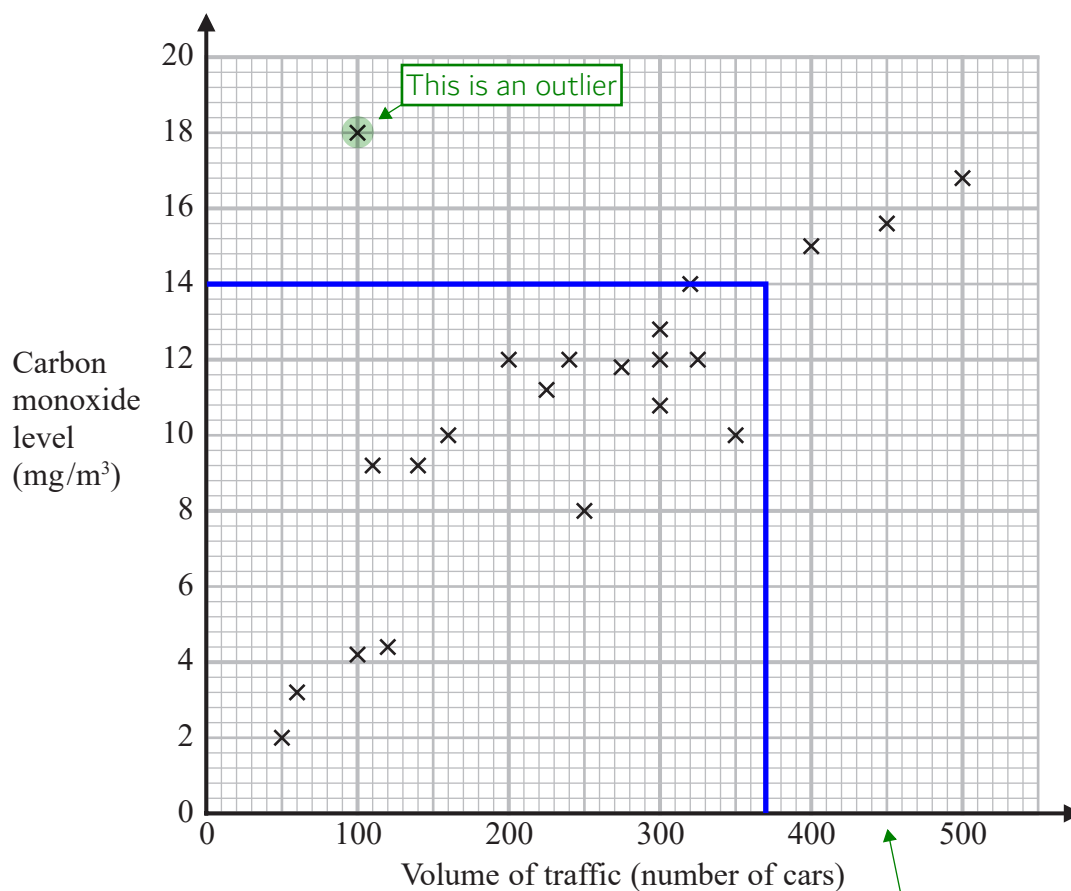

One point is an outlier.

- (a) Write down the coordinates of this point.

(..... 100 , 18)
(1)

For another day, 370 cars pass the point on the road.

- (b) Estimate the carbon monoxide level for this day.

Reading up to a point on the graph which is about in the middle of the surrounding data then reading across

..... 14 mg/m³
(2)

Alfie says,

“Because there is an outlier, there is no correlation.”

(c) Is Alfie correct?

You must give a reason for your answer.

No, this point can be ignored

(1)

(Total for Question 21 is 4 marks)



22 Natalie makes potato cakes in a restaurant.

She mixes potato, cheese and onion so that

$$\text{weight of potato} : \text{weight of cheese} : \text{weight of onion} = 9 : 2 : 1$$

Natalie needs to make 6000 g of potato cakes.

Cheese costs £2.25 for 175 g.

Work out the cost of the cheese needed to make 6000 g of potato cakes.

$$9 + 2 + 1$$

Adding up the parts of the ratio finds that there are 12 parts in total which represent the 6000 g

$$6000 \div 12$$

Dividing the 6000 g by the 12 parts finds that 1 part of the ratio is worth 500 g

$$500 \times 2$$

Multiplying the value of 1 part of the ratio by 2 finds that the 2 parts which represent the cheese are worth 1000 g

$$1000 \div 175$$

Dividing the 1000 g of cheese by the 175 g finds that 5.7... lots of the 175 g of cheese is needed

$$5.7... \times 2.25$$

5.7... lots of the £2.25 finds the cost of the cheese. The question does not say that the cheese is in packs so it is fine to have a decimal as the cheese could be cut

Rounding the cost to the nearest penny

£.....12.86

(Total for Question 22 is 4 marks)

23 (a) Write 4.5×10^5 as an ordinary number.

Type into the calculator

450000

(1)

(b) Write 0.007 in standard form.

Type into the calculator

7×10^{-3}

(1)

(c) Work out $4.2 \times 10^3 + 5.3 \times 10^2$
Give your answer in standard form.

Typing into calculator gives 4730. Formatting it as ENG notation gives it in standard form in this case

4.73×10^3

(2)

(Total for Question 23 is 4 marks)

24 A water tank is empty.
Anil needs to fill the tank with 2400 litres of water.

Company **A** supplies water at a rate of 8 litres in 1 minute 40 seconds.
Company **B** supplies water at a rate of 2.2 gallons per minute.

1 gallon = 4.54 litres

Company **A** would take more time to fill the tank than Company **B** would take to fill the tank.

How much more time?

Give your answer in minutes correct to the nearest minute.

$$2400 \div 8$$

Dividing the 2400 litres by the 8 litres finds that the 2400 litres is 300 lots of the 8 litres

$$300 \times 0^{\circ}1^{\circ}40^{\circ}$$

Doing 300 lots of the 1 minutes 40 seconds finds that Company A would take 8 hours 20 minutes. Entering the time into the calculator as a sexagesimal gives $8^{\circ}20^{\circ}0''$

$$8^{\circ}20^{\circ} \times 60 = 500$$

1 hour = 60 minutes. So multiplying the time by 60 converts it to 500 minutes

$$2.2 \times 4.54$$

Converting the 2.2 gallons to 9.988 litres

$$2400 \div 9.988$$

Dividing the 2400 litres by the 9.988 litres finds that the 2400 litres is 240.2... lots of the 9.988 litres. As each lot is a minute, company B would take 240.2... minutes

$$500 - 240.2...$$

Subtracting the 240.2... minutes it would take Company B from the 500 minutes it would take Company A finds how many more minutes it would take Company A

259.7... is rounded to the nearest minute

260

..... minutes

(Total for Question 24 is 4 marks)

25 The first four terms of a Fibonacci sequence are

$$a \quad 2a \quad 3a \quad 5a$$

The sum of the first five terms of this sequence is 228

Work out the value of a .

$$a + 2a + 3a + 5a + 8a$$

Adding together the first five terms. The 5th term is $8a$ as $3a + 5a = 8a$. In a Fibonacci sequence, the two previous terms are added to get the next term

$$19a = 228$$

Collecting like terms and setting it equal to 228

Dividing both sides by 19 finds a

12

(Total for Question 25 is 3 marks)

- 26 In a bag there are only red counters, blue counters, green counters and pink counters. A counter is going to be taken at random from the bag.

The table shows the probabilities of taking a red counter or a blue counter.

Colour	red	blue	green	pink
Probability	0.05	0.15	0.5	0.3

The probability of taking a green counter is 0.2 more than the probability of taking a pink counter.

- (a) Complete the table.

See next page for method

(2)

There are 18 blue counters in the bag.

- (b) Work out the total number of counters in the bag.

$$x \times 0.15 = 18$$

Let x be the total number of counters. Multiplying this by the probability of blue expresses the number of blue counters, which is 18

Dividing both sides by 0.15 finds that x is 120. This is the total number of counters

120

(2)

(Total for Question 26 is 4 marks)

$1 - 0.05 - 0.15 = 0.8$ ← It is certain to get one of the four colours so the probabilities must add up to 1. Subtracting the probability for red or blue from 1 finds that the probability for green or pink is 0.8

$p + p + 0.2$ ← Let p be the probability for pink. $p + 0.2$ must be the probability for green. Adding these expresses the probability for green or pink

$2p + 0.2 = 0.8$ ← Collecting like terms and setting equal to the 0.8

$2p = 0.6$ ← Subtracting 0.2 from both sides gets the p term on its own

$p = 0.3$ ← Dividing both sides by 2 gets p on its own. So the probability of pink is 0.3

$0.3 + 0.2$ ← Adding 0.2 to the probability of pink finds that the probability of green is 0.5

DO NOT WRITE IN THIS AREA

27 The diagram shows a sector $OPQR$ of a circle, centre O and radius 8 cm.

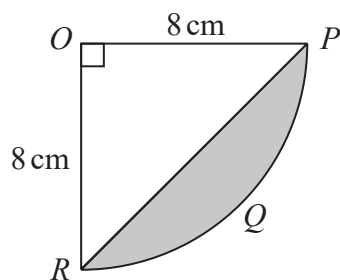

OPR is a triangle.

Work out the area of the shaded segment PQR .

Give your answer correct to 3 significant figures.

$\pi \times 8^2$ ← Area of circle = $\pi \times \text{radius}^2$. So the area of the whole circle is $64\pi \text{ cm}^2$

$64\pi \div 4 = 16\pi$ ← The sector $OPQR$ is $1/4$ of the whole circle. So dividing the area of the whole circle by 4 finds that the area of the sector is $16\pi \text{ cm}^2$

$0.5 \times 8 \times 8$ ← Area of triangle = $1/2 \times \text{base} \times \text{height}$. So the area of the triangle OPR is 32 cm^2

$16\pi - 32$ ← Subtracting the area of the triangle OPR from the sector $OPQR$ leaves the area of the segment PQR

18.26... is given correct to 3 significant figures

.....18.3..... cm^2

(Total for Question 27 is 4 marks)

DO NOT WRITE IN THIS AREA

DO NOT WRITE IN THIS AREA



28 Sketch the graph of $y = \frac{1}{x}$

Using table mode on the calculator. Define $f(x) = 1/x$. Start: -5. End: 5. Step: 1. This gives a table of values for the equation and gives an idea of what it looks like

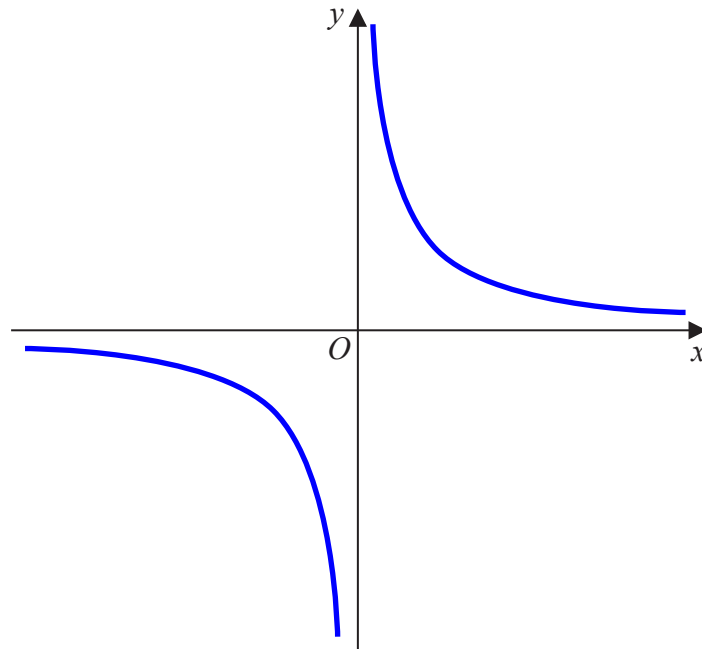

(Total for Question 28 is 2 marks)

TOTAL FOR PAPER IS 80 MARKS

DO NOT WRITE IN THIS AREA

DO NOT WRITE IN THIS AREA

DO NOT WRITE IN THIS AREA

