

Please check the examination details below before entering your candidate information

Candidate surname

Other names

Centre Number

Candidate Number

Pearson Edexcel
Level 1/Level 2 GCSE (9–1)

--	--	--	--	--

--	--	--	--

Thursday 4 June 2020

Morning (Time: 1 hour 30 minutes)

Paper Reference **1MA1/2F**

Mathematics

Paper 2 (Calculator)

Foundation Tier

You must have: Ruler graduated in centimetres and millimetres, protractor, pair of compasses, pen, HB pencil, eraser, calculator. Tracing paper may be used.

Total Marks

Instructions

- Use **black** ink or ball-point pen.
- **Fill in the boxes** at the top of this page with your name, centre number and candidate number.
- Answer **all** questions.
- Answer the questions in the spaces provided – *there may be more space than you need.*
- You must **show all your working**.
- Diagrams are **NOT** accurately drawn, unless otherwise indicated.
- **Calculators may be used.**
- If your calculator does not have a π button, take the value of π to be 3.142 unless the question instructs otherwise.



Information

- The total mark for this paper is 80
- The marks for **each** question are shown in brackets – *use this as a guide as to how much time to spend on each question.*

Advice

- Read each question carefully before you start to answer it.
- Keep an eye on the time.
- Try to answer every question.
- Check your answers if you have time at the end.

Turn over ►

P62275A

©2020 Pearson Education Ltd.

1/1/1/

.CG Maths.

Hints



Pearson

Please note that these worked solutions have neither been provided nor approved by Pearson Education and may not necessarily constitute the only possible solutions. Please refer to the original mark schemes for full guidance.

Any writing in blue indicates what must be written in order to answer the questions and get the marks. The worked solutions have been designed to show the smallest amount of work which needs to be done to answer the question.

Anything written in green in a cloud doesn't have to be written in the exam.

Anything written in orange in a rectangle doesn't have to be written in the exam and is there to show what should be put into a calculator or measured using a ruler or protractor.

If you find any mistakes or have any requests or suggestions, please send an email to curtis@cgmaths.co.uk

Answer ALL questions.

Write your answers in the spaces provided.

You must write down all the stages in your working.

1 Write 0.37 as a fraction.

Type into the calculator then press the SD button

.....
(Total for Question 1 is 1 mark)

2 Write 29381 correct to the nearest 1000

The 9 is in the thousands place. Does the 3 after cause it to round up or down? Everything after the 9 once it has been rounded is ignored and set to 0

.....
(Total for Question 2 is 1 mark)

3 Simplify $3e - e + 4e$

(3 lots of e) - (1 lot of e) + (4 lots of e).
How many lots of e will there be?

.....
(Total for Question 3 is 1 mark)

4 Write $\frac{1}{4}$ as a percentage.

$\frac{1}{4}$ is a common conversion so is one we could just know. But if not we can work out $\frac{1}{4}$ of 100 as percent is out of 100

..... %
(Total for Question 4 is 1 mark)

DO NOT WRITE IN THIS AREA

DO NOT WRITE IN THIS AREA

DO NOT WRITE IN THIS AREA

5 Here is a list of numbers.

3 4 9 18 27 30 36

From the numbers in the list, write down a cube number.

We could know the cube numbers up to 125, which is 5^3 , as these are quite common. If we don't know them, we can go through them until we get to one on the list. $1^3 = 1$. $2^3 = 8$...

(Total for Question 5 is 1 mark)

6 Liz is watching a film at the cinema.

The film started at 1430

The film is 105 minutes long.

When the film ends, Liz takes 20 minutes to get to the bus stop.

A bus leaves the bus stop at 1645

Does Liz get to the bus stop in time to get this bus?

You must show all your working.

$$14:30 + 0:105 + 0:20$$

FACT B



To put time into the calculator, enter the hours then press the button on the left. Then enter the minutes and press the button on the left again. It should be entered as: $14^{\circ}30^{\circ} + 0^{\circ}105^{\circ} + 0^{\circ}20^{\circ}$. The answer will be returned in time in the format hours-minutes-seconds

(Total for Question 6 is 3 marks)

7 Farhad, George and Tom each did a test.

Here are their marks for the test.

Farhad	74
George	77
Tom	72

George drew this bar chart to show the marks they got.
The bar chart is **not** fully correct.

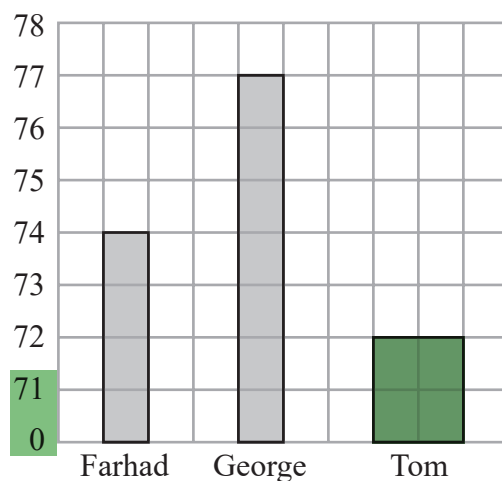

Write down **two** things that are wrong with George's bar chart.

1. There is something wrong with the bar for Tom

2. There is something wrong with the scale

(Total for Question 7 is 2 marks)

8

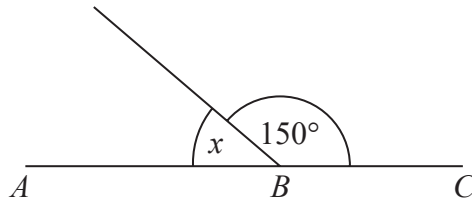

ABC is a straight line.

(a) (i) Work out the size of the angle marked x .

Angles around a point on a straight line add up to as many degrees as are in half a turn

.....
(1)

(ii) Give a reason for your answer.

Angles around a point on a straight line add up to...

.....

.....

..... (1)

The diagram below is wrong.

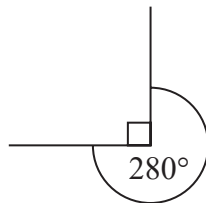

(b) Explain why.

$90 + 280 = \dots$

.....

.....

..... (1)

(Total for Question 8 is 3 marks)

DO NOT WRITE IN THIS AREA

- 9 This scale can be used to change between kilometres and miles.

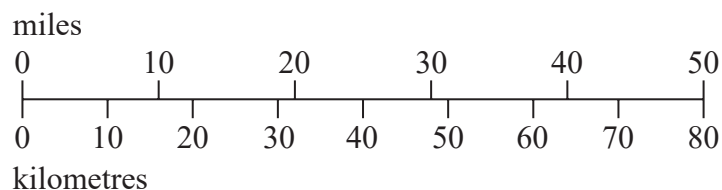

- (a) Use the scale to change 40 kilometres to miles.

The 40km is halfway between 20 and 30 miles

..... miles
(1)

Here is an approximate rule to change from kilometres to miles.

Divide the distance in kilometres by 10 and then multiply by 6

- (b) Use this approximate rule to change 40 kilometres to miles.

$$\frac{40}{10} \times 6$$

..... miles
(2)

- (c) Compare your answer to part (b) with your answer to part (a).

Are they close together or far away from each other?

.....
(1)

(Total for Question 9 is 4 marks)

DO NOT WRITE IN THIS AREA

DO NOT WRITE IN THIS AREA

DO NOT WRITE IN THIS AREA

10 (a) Solve $3m = 36$

Do the opposite of multiplying by 3 to both sides to eliminate the 3 from the left side

$m = \dots\dots\dots$
(1)

(b) Solve $7 - x = 3$

What must be subtracted from 7 to get 3?

$x = \dots\dots\dots$
(1)

(Total for Question 10 is 2 marks)

11 Here is a cuboid.

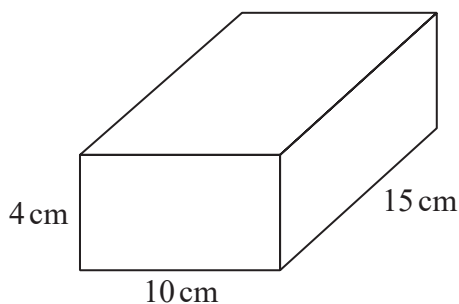

Work out the volume of the cuboid.

Volume of cuboid = length x width x height
Don't forget to include a unit. cm x cm x cm

.....

(Total for Question 11 is 3 marks)

12 Lucy uses a code to open a lock.

The code is a letter followed by a 2-digit number.

The letter is L or U.

The number is a prime number between 20 and 30

Write down all the possibilities for Lucy's code.

FACT B

0 3 99

To check if a number is prime: enter the number, press =, press SHIFT then the button on the left. If it comes back as itself, it is prime. If it comes back as other numbers multiplied together, it isn't prime

Systematically list the possibilities

(Total for Question 12 is 2 marks)

13 A machine fills bags with sweets.

There are 4275 sweets.

There are 28 sweets in each full bag.

The machine fills as many bags as possible.

How many sweets are left?

See how many lots of 28 go into 4275 and convert the result into a mixed number. The whole number is how many bags were filled. The remainder is the numerator of the fraction part when the denominator is 28

(Total for Question 13 is 3 marks)

14 The table gives information about the number of goals scored by each of three teams.

Team	Number of goals
City	50
Rovers	45
United	25

Draw an accurate pie chart for this information.

There are 360 degrees in total in a pie chart. Divide this by the total number of goals to work out how many degrees represent each goal. Work out the angle for each team and draw on the angles using a protractor

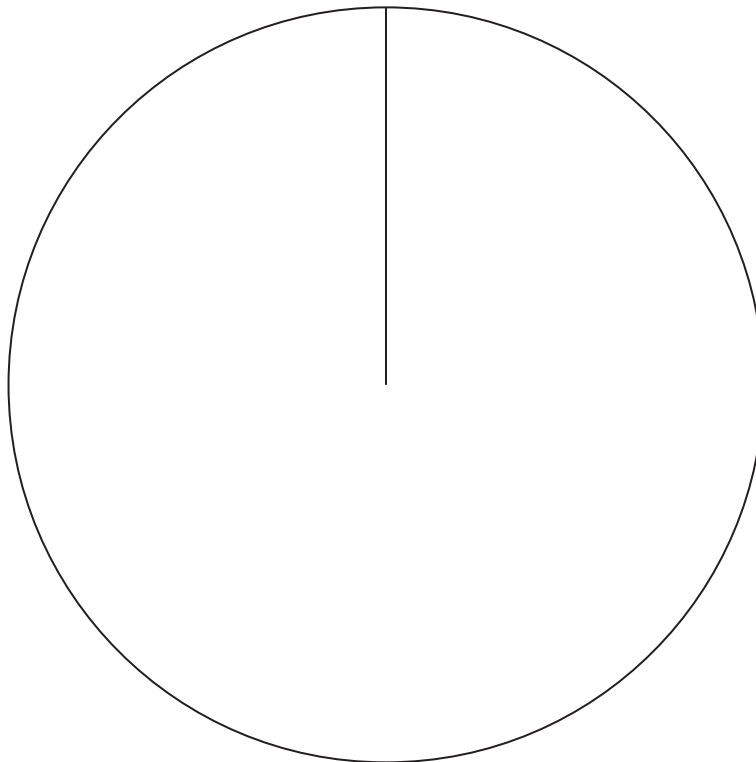

(Total for Question 14 is 3 marks)

DO NOT WRITE IN THIS AREA

DO NOT WRITE IN THIS AREA

DO NOT WRITE IN THIS AREA

15 $T = 3x + 4y$

(a) Work out the value of T when $x = 5$ and $y = -7$

Substitute x for 5 and y for -7

.....
(2)

(b) Work out the value of y when $T = 38$ and $x = 6$

Rearrange the equation to make y the subject by following BIDMAS backward and doing the opposite operations to get rid of everything apart from y on the side y is on. Then substitute T for 38 and x for 6

.....
(2)

(Total for Question 15 is 4 marks)

DO NOT WRITE IN THIS AREA

DO NOT WRITE IN THIS AREA

DO NOT WRITE IN THIS AREA

16 An exam has two papers, Paper 1 and Paper 2

Paper 1 has 60 marks.

Paper 2 has 90 marks.

The pass mark is $\frac{2}{3}$ of the total number of marks.

Danielle gets 70% of the marks for Paper 1

How many of the marks for Paper 2 must Danielle get in order to get the pass mark?

Subtracting the number of marks she got on Paper 1 from the pass mark gives the number of marks she must get on Paper 2

(Total for Question 16 is 4 marks)

- 17 Scott wants to make orange juice.
He is going to buy boxes of oranges.

There are 24 oranges in each box of oranges.

30 oranges make 2 litres of orange juice.

Scott needs to buy enough oranges to make 8 litres of orange juice.

- (a) Work out the number of boxes of oranges that Scott needs to buy.
You must show all your working.

Work out how many lots of 2 litres go into the 8 litres. This tells us how many lots of 30 oranges are needed. Next work out how many oranges are needed. Then work out how many lots of 24 this is. This is how many boxes are needed

.....
(3)

Scott also buys
1260 apples
280 bananas

- (b) Write down the ratio of the number of apples that Scott buys to the number of bananas that he buys.
Give your ratio in its simplest form.

Typing 1260/280 into the calculator
will give us a simplified fraction

Fractions simplify in a similar way to ratios

.....
(2)

(Total for Question 17 is 5 marks)

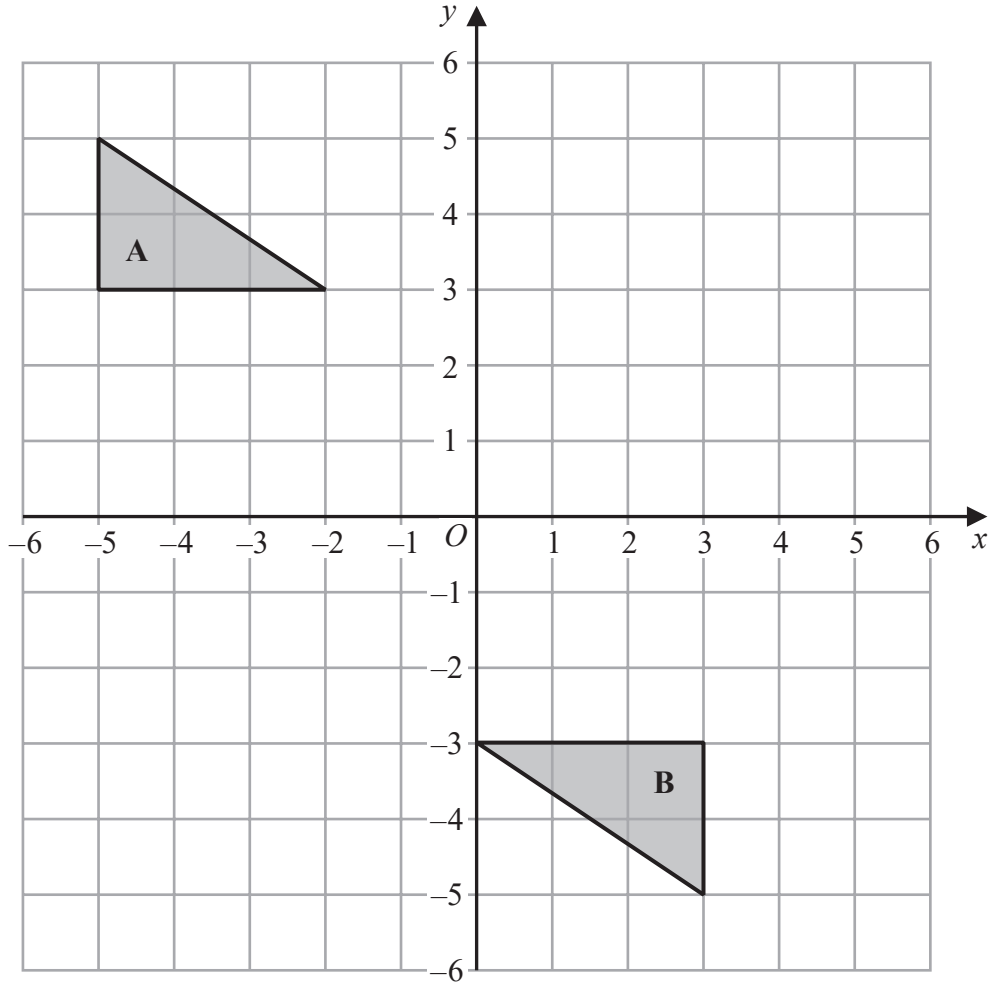

Describe fully the single transformation that maps triangle **A** onto triangle **B**.

Rotation...

We need to describe how much it has rotated by and around which point

(Total for Question 18 is 2 marks)

19 Adam, Linda and Rytis share an amount of money.

Linda gets three times as much money as Rytis gets.
Linda gets half as much money as Adam gets.

What fraction of the amount of money does Linda get?

Write the ratio of money for Adam : Linda : Rytis. Set Rytis to 1 part.
The fraction of the amount of money Linda gets is the amount of parts she gets in the ratio out of the total number of parts in the ratio

.....
(Total for Question 19 is 2 marks)

20 Pens and pencils are sold in a shop.

12 pencils cost £1.80

The ratio of the cost of a pen to the cost of a pencil is 7:3

Work out the cost of 5 pens.

Work out the cost of 1 pencil. 3 parts of the ratio represent the cost of a pencil.
Work out what 1 part represents. Then work out what 7 parts represent, which is the cost of a pen. Multiply this by 5 as we need to find the cost of 5 pens

£.....

(Total for Question 20 is 4 marks)

21 (a) Write 84 as a product of its prime factors.

FACT B Enter 84 in the calculator then press =. Then
press SHIFT then the button on the left

.....
(2)

(b) Find the lowest common multiple (LCM) of 60 and 84

Express both 60 and 84 as a product of prime factors in index form. 84 was done in the previous question. The LCM is the highest power of each prime multiplied together

.....
(2)

(Total for Question 21 is 4 marks)

22 $\mathcal{E} = \{1, 2, 3, 4, 5, 6, 7, 8, 9, 10\}$

$A = \{\text{even numbers}\}$

$B = \{\text{factors of } 10\}$

Enter all the numbers from 1 to 10

Whole numbers 10 can be divided by and get a whole number answer

(a) Complete the Venn diagram for this information.

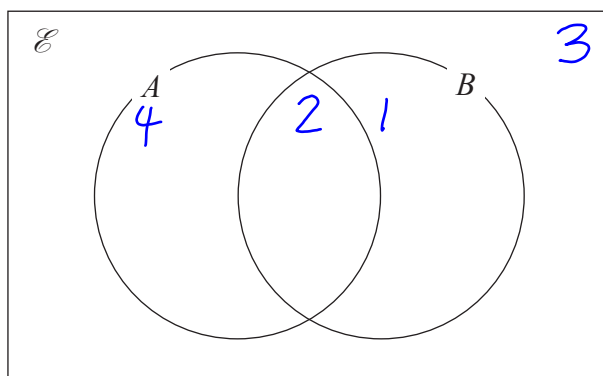

A number is chosen at random from the universal set, \mathcal{E}

Out of all of the numbers in the diagram

(b) Find the probability that this number is in the set $A \cap B$

The fraction of numbers in the intersection of A and B is the probability

The intersection of A and B: both A and B at the same time

(2)

(Total for Question 22 is 5 marks)

23 Carlo puts tins into small boxes and into large boxes.

He puts 6 tins into each small box.

He puts 20 tins into each large box.

Carlo puts a total of 3000 tins into the boxes so that

$$\text{number of tins in small boxes} : \text{number of tins in large boxes} = 2:3$$

Carlo says that less than 30% of the boxes filled with tins are large boxes.

Is Carlo correct?

You must show all your working.

There are 5 parts in total in the ratio and these represent a total of 3000 tins. Work out what 1 part represents. Then work out what the 2 and 3 parts represent to get how many tins are in the small and large boxes. Work out how many small and large boxes these will fill using the fact there are 6 in a small box and 20 in a large box. Express the number of large boxes as a fraction of the total number of boxes then convert it into a percentage. Compare this percentage to the 30% to see if it is less

(Total for Question 23 is 5 marks)

24 (a) Complete the table of values for $y = 5 - x^3$

Press MENU then 3 to enter table mode. Enter $f(x) = 5 - x^3$ then press =. Ignore $g(x)$ by pressing =. Start: -2, End: 2, Step: 1. Enter the number and press = to set each of these

x	-2	-1	0	1	2
y		6			

(2)

(b) On the grid below, draw the graph of $y = 5 - x^3$ for values of x from -2 to 2

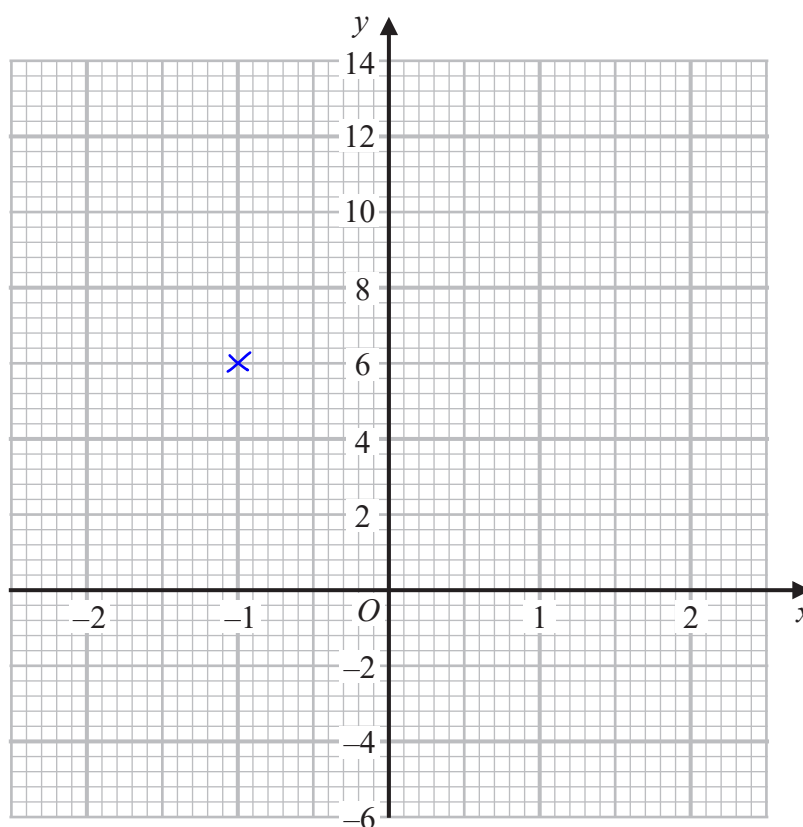

(2)

(Total for Question 24 is 4 marks)

25

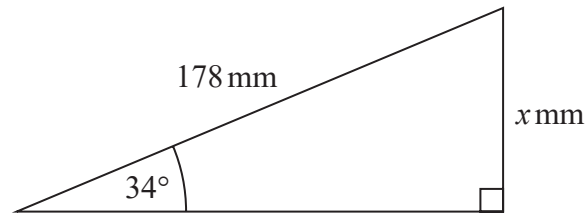

Work out the value of x .
Give your answer correct to 1 decimal place.

SOH CAH TOA

Writing SOH CAH TOA as formula triangles. Tick what we have and what we are trying to find. If there are two ticks on one of the formula triangles, we can use that one. To use the formula triangle, cover over what we are trying to find and the rest will tell us what to do.

S: sin of the angle, C: cos of the angle, T: tan of the angle, O: opposite, H: Hypotenuse, A: adjacent

(Total for Question 25 is 2 marks)

26 $\mathbf{a} = \begin{pmatrix} 3 \\ 4 \end{pmatrix}$ $\mathbf{b} = \begin{pmatrix} 5 \\ -2 \end{pmatrix}$

Find $2\mathbf{a} - 3\mathbf{b}$ as a column vector.

$$w \begin{pmatrix} x \\ y \end{pmatrix} = \begin{pmatrix} wx \\ wy \end{pmatrix}$$

$$\begin{pmatrix} x \\ y \end{pmatrix} - \begin{pmatrix} v \\ w \end{pmatrix} = \begin{pmatrix} x - v \\ y - w \end{pmatrix}$$

$\begin{pmatrix} \dots \\ \dots \\ \dots \end{pmatrix}$

(Total for Question 26 is 2 marks)

27 The diagram shows a right-angled triangle and a quarter circle.

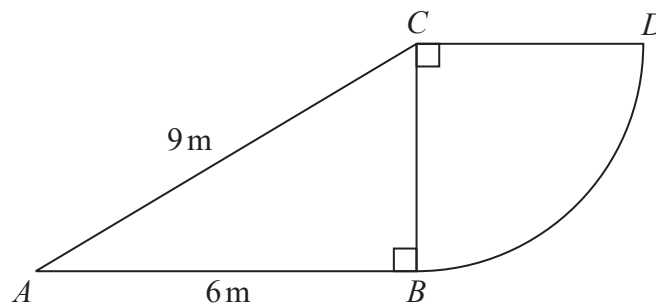

The right-angled triangle ABC has angle $ABC = 90^\circ$
The quarter circle has centre C and radius CB .

Work out the area of the quarter circle.
Give your answer correct to 3 significant figures.
You must show all your working.

Area of circle = πr^2 , where r is the radius. r is side CB , which is found by using Pythagoras' Theorem in the right-angled triangle ABC . $a^2 + b^2 = c^2$, where a and b are the shorter sides and c is the longest side. Find $1/4$ of the area of the circle as it is a quarter circle

..... m²

(Total for Question 27 is 4 marks)

DO NOT WRITE IN THIS AREA

DO NOT WRITE IN THIS AREA

DO NOT WRITE IN THIS AREA

DO NOT WRITE IN THIS AREA

DO NOT WRITE IN THIS AREA

DO NOT WRITE IN THIS AREA

28 Each exterior angle of a regular polygon is 15°

Work out the number of sides of the polygon.

The sum of the exterior angles for any polygon is 360. There are as many sides as exterior angles

.....
(Total for Question 28 is 2 marks)

29 Write down the gradient of the line with equation $y = 2x + 3$

The general equation of a straight line is $y = mx + c$, where m is the gradient and c is the y -intercept. The equation is already in this form

.....
(Total for Question 29 is 1 mark)

TOTAL FOR PAPER IS 80 MARKS