

Please check the examination details below before entering your candidate information

Candidate surname

Other names

Centre Number

Candidate Number

--	--	--	--	--

--	--	--	--

Pearson Edexcel Level 1/Level 2 GCSE (9–1)

Time 1 hour 30 minutes

Paper
reference

1MA1/3F

Mathematics PAPER 3 (Calculator) Foundation Tier

You must have: Ruler graduated in centimetres and millimetres, protractor, pair of compasses, pen, HB pencil, eraser, calculator, Formulae Sheet (enclosed). Tracing paper may be used.

Total Marks

Instructions

- Use **black** ink or ball-point pen.
- **Fill in the boxes** at the top of this page with your name, centre number and candidate number.
- Answer **all** questions.
- Answer the questions in the spaces provided – *there may be more space than you need.*
- You must **show all your working**.
- Diagrams are **NOT** accurately drawn, unless otherwise indicated.
- **Calculators may be used.**
- If your calculator does not have a π button, take the value of π to be 3.142 unless the question instructs otherwise.



Information

- The total mark for this paper is 80
- The marks for **each** question are shown in brackets – *use this as a guide as to how much time to spend on each question.*

Advice

- Read each question carefully before you start to answer it.
- Try to answer every question.
- Check your answers if you have time at the end.

Turn over ►

P68724A

©2022 Pearson Education Ltd.

B:1/1/1/1/1/1/

.CG Maths.
Worked Solutions

Pearson

Please note that these worked solutions have neither been provided nor approved by Pearson Education and may not necessarily constitute the only possible solutions. Please refer to the original mark schemes for full guidance.

Any writing in blue should be written in the exam.

Anything written in green in a rectangle doesn't have to be written in the exam.

If you find any mistakes or have any requests or suggestions, please send an email to curtis@cgmaths.co.uk

Answer ALL questions.

Write your answers in the spaces provided.

You must write down all the stages in your working.

- 1 Write the following numbers in order of size.
Start with the smallest number.

0.410 0.500 0.460 0.408

Writing the decimals to the same number of decimal places can make them easier to compare

0.408, 0.41, 0.46, 0.5

(Total for Question 1 is 1 mark)

- 2 Write down the value of the 2 in the number 12345

The 2 is in the thousands place

2000

(Total for Question 2 is 1 mark)

- 3 Write $\frac{4}{5}$ as a decimal.

$\frac{4}{5} = 0.8$

0.8

(Total for Question 3 is 1 mark)

- 4 Write 19.4949 correct to the nearest whole number.

The 4 in the tenths place after the 9 in the units place causes it to round down and stay as a 9. Everything after the units is then ignored

19

(Total for Question 4 is 1 mark)

- 5 Here is a list of numbers.

5 11 18 22 29

From the list, write down a multiple of 3

$6 \times 3 = 18$, so 18 is a multiple of 3

18

(Total for Question 5 is 1 mark)

DO NOT WRITE IN THIS AREA

DO NOT WRITE IN THIS AREA

DO NOT WRITE IN THIS AREA



6 The graph shows information about the average monthly temperature, in °C, in Amman.

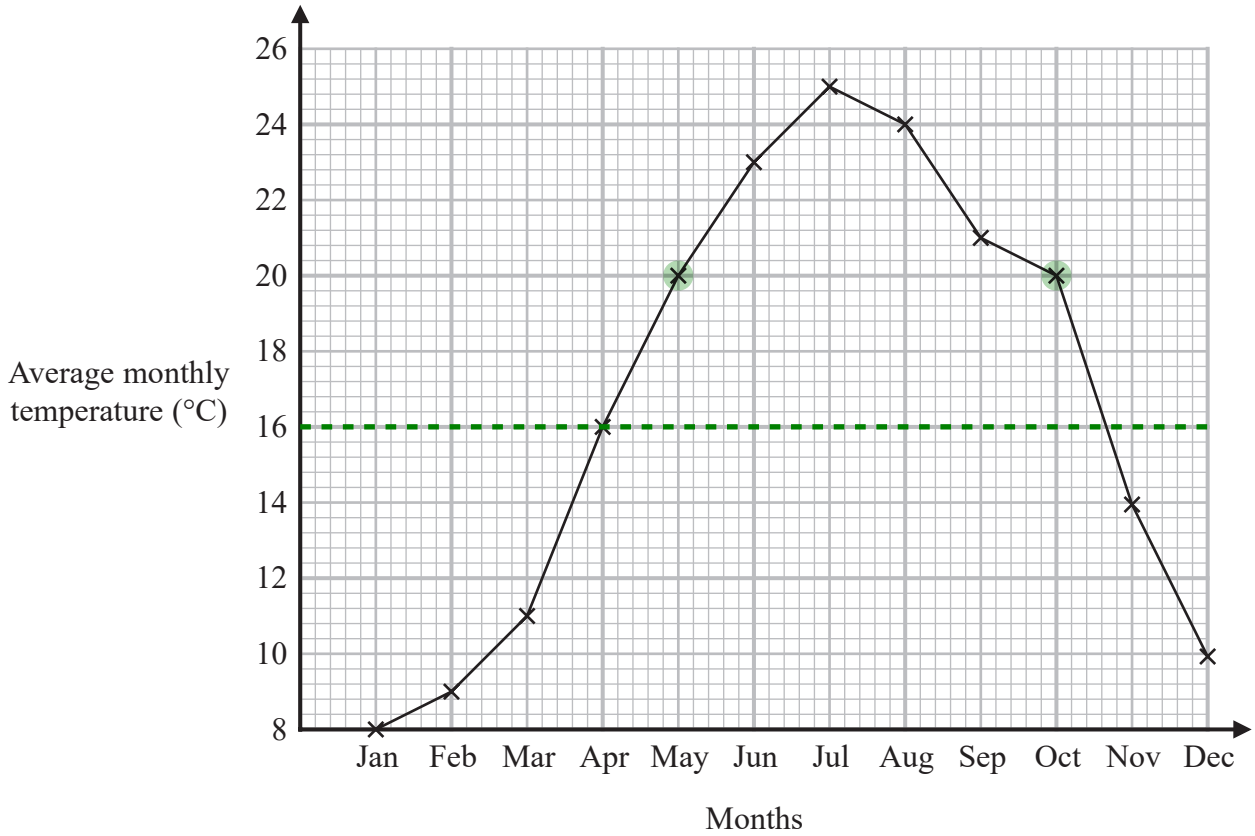

(a) For how many months was the average monthly temperature greater than 16°C?

Every cross above the dashed line is greater than 16°C

6

(1)

(b) Write down the two months that had the same average monthly temperature.

The two highlighted points had the same average monthly temperature

May

and October

(1)

(Total for Question 6 is 2 marks)

7 208 bars of chocolate were sold from a shop.

$\frac{1}{4}$ of these bars of chocolate were large bars.

The rest of the bars of chocolate were small bars.

All the large bars of chocolate were sold for £1 each.

All the small bars of chocolate were sold for 60p each.

Work out the total amount of money for which the 208 bars of chocolate were sold.

Give your answer in pounds.

$$\frac{1}{4} \times 208 = 52$$

Working out that $\frac{1}{4}$ of the bars is 52, so there are this many large bars. 'Of' means to multiply.

$$208 - 52 = 156$$

Subtracting the 52 large bars from the 208 bars works out that there are 156 small bars

$$52 \times 1 = 52$$

Multiplying the 52 large bars by the cost of each one works out that the large bars were sold for £52 in total

$$156 \times 0.60 = 93.60$$

Multiplying the 156 small bars by the cost of each one in pounds works out that the small bars were sold for £93.60 in total. The 60p was converted into pounds using the fact that there is 100p in £1, so it was divided by 100

$$52 + 93.60$$

Adding the £52 the large bars were sold for and the £93.60 the small bars were sold for works out the total amount of money which the 208 bars were sold for

£..... 145.60

(Total for Question 7 is 3 marks)

- 8 Four students play a game.
The table shows the number of points each student has.

Student	Ali	Barbara	Calliope	Danesh
Number of points	143	+ 121	+ 45	+ 19

$= 328$

Barbara has more points than Danesh.

- (a) How many more?

$121 - 19$ ← Subtracting the number of points Danesh has from the number of points Barbara has works out the difference between them and therefore how many more Barbara has

102

(1)

- (b) Work out the mean number of points.

$328 \div 4$ ← Mean = total \div number, where total is the total number of points and number is the number of students. The total is 328 and the number of students is 4

82

(2)

(Total for Question 8 is 3 marks)

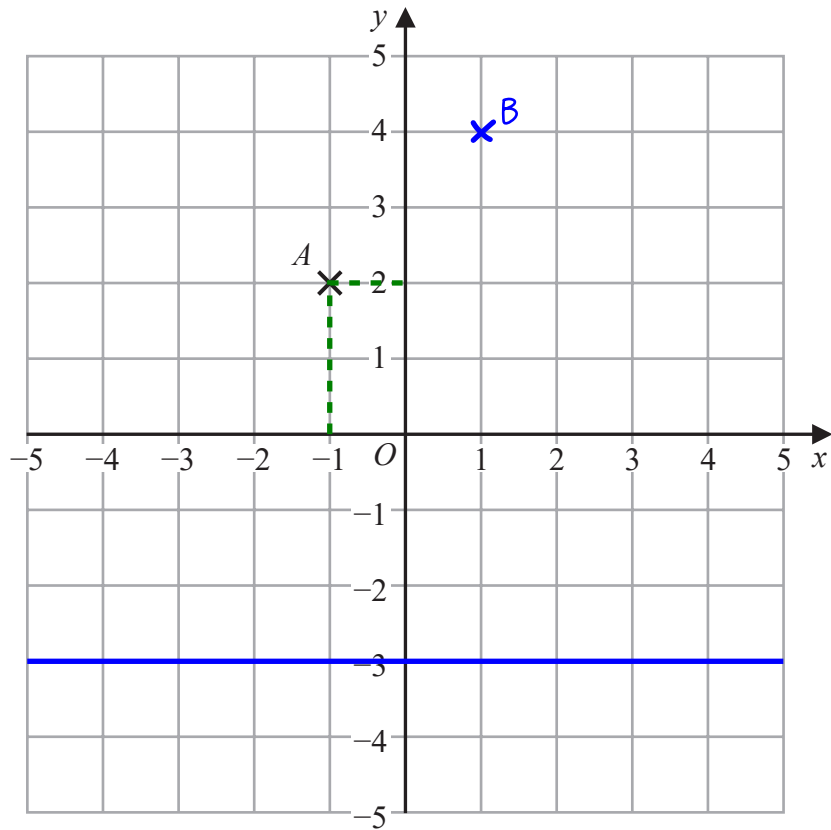

- (a) Write down the coordinates of point A .

x-coordinate	y-coordinate
↓	↓
(..... -1)	(..... 2)
	(1)

- (b) On the grid, mark with a cross (\times) the point $(1, 4)$
Label this point B .

(1)

- (c) On the grid, draw the line with equation $y = -3$

The y-coordinates of all points on the line are -3

(1)

(Total for Question 9 is 3 marks)

10 Here are the first three terms of a sequence.

20 $\boxed{-4}$ 16 $\boxed{-3}$ 13 $\boxed{-2}$ $\boxed{-1}$

(i) Write down two numbers that could be the 4th and 5th terms of this sequence.

..... 11 , 10
(1)

(ii) Write down the rule you used to get your numbers.

Subtract 1 less each time

(1)

(Total for Question 10 is 2 marks)

11 Here is a cuboid.

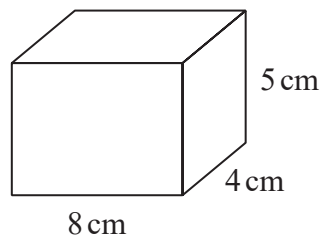

Work out the volume of the cuboid.

$8 \times 4 \times 5$ ← Volume of cuboid = length x width x height

..... 160 cm^3

(Total for Question 11 is 2 marks)

12 Amol, Gemma and Harry each have a number of sweets.

The number of sweets that Gemma has is 6 times the number of sweets that Amol has.
The number of sweets that Harry has is half the number of sweets that Gemma has.

Write down the ratio

the number of sweets : the number of sweets : the number of sweets
that Amol has : that Gemma has : that Harry has

Amol has the least number of sweets so setting 1 part to Amol's number of sweets. Gemma has 6 times this and $1 \times 6 = 6$ so Gemma has 6 parts. Harry has half this and $6 \div 2 = 3$ so Harry has 3 parts

..... 1:6:3

(Total for Question 12 is 2 marks)

DO NOT WRITE IN THIS AREA

DO NOT WRITE IN THIS AREA

DO NOT WRITE IN THIS AREA

13 $ABCD$ is a quadrilateral.

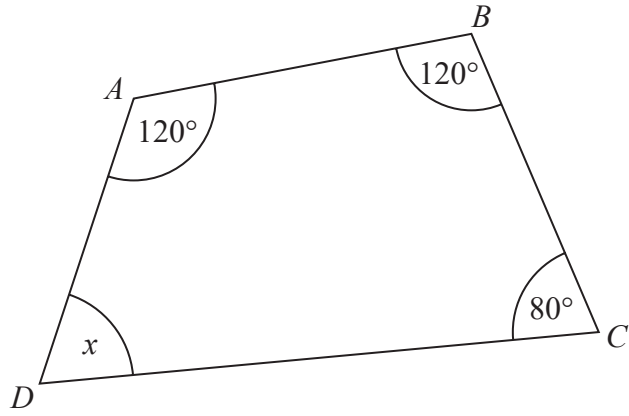

(a) (i) Work out the size of angle x .

$360 - 120 - 120 - 80$ ← There are 360° in total in a 4-sided shape. Subtracting the other angles from 360 leaves the angle x

40 °
(1)

(ii) Give a reason for your answer.

There are 360° in total in a 4-sided shape

.....

.....

.....

(1)

The diagram below shows a triangle.

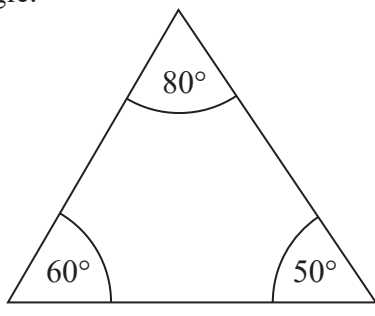

The diagram is wrong.

(b) Explain why.

$60 + 80 + 50 = 190$

There are 180° in total in a triangle. This one apparently has 190°

.....

.....

(1)

(Total for Question 13 is 3 marks)

14 You can use this graph to change between ounces and grams.

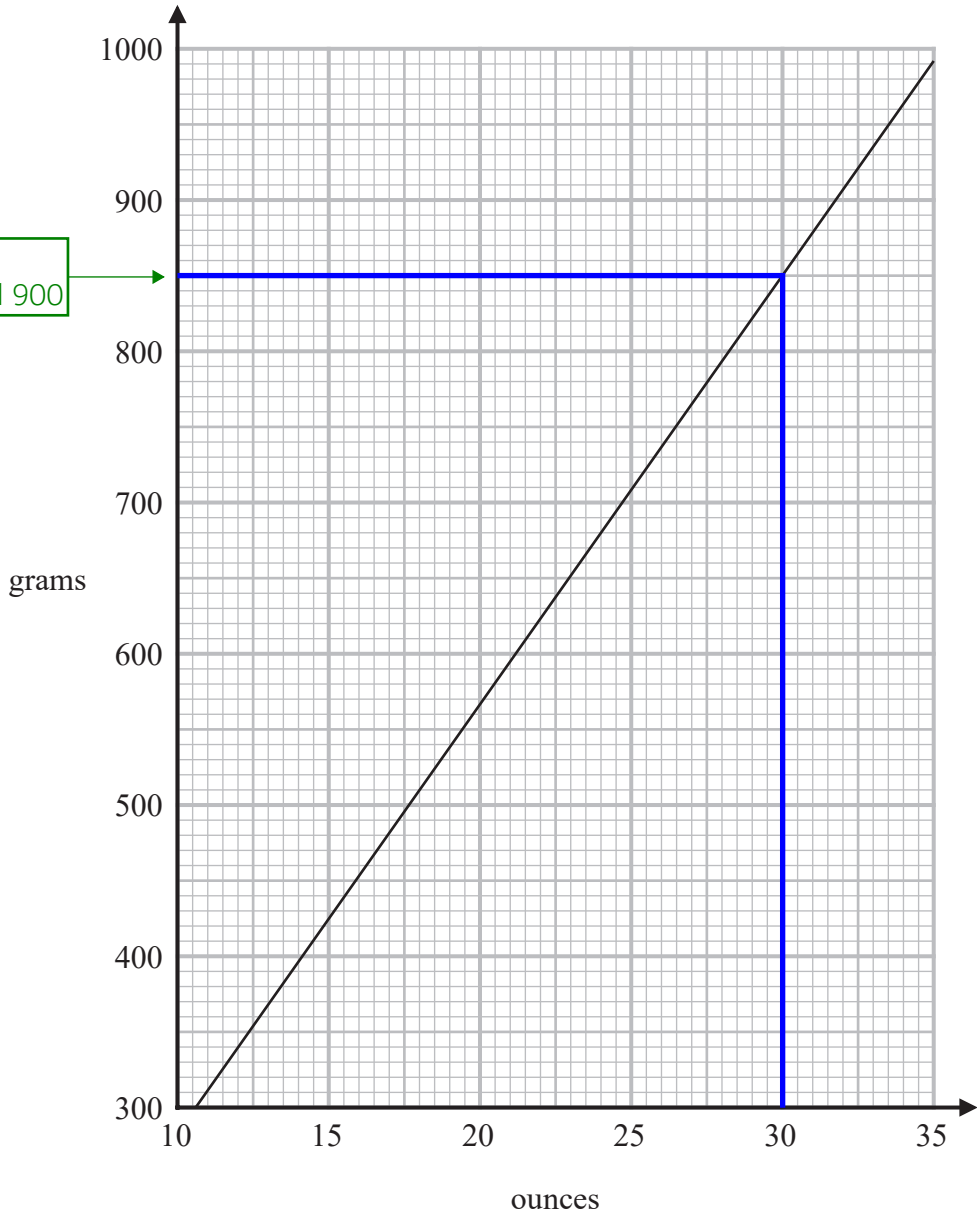

DO NOT WRITE IN THIS AREA

DO NOT WRITE IN THIS AREA

DO NOT WRITE IN THIS AREA

(a) Change 850 grams to ounces.

Reading across from 850 grams to the line then down to the ounces

..... 30 ounces
(1)

(b) Change 80 ounces to grams.

$$\frac{850}{30} \times 80$$

From the last part of the question, 850 grams is 30 ounces. Dividing the 850 grams by the 30 ounces works out what 1 ounce is in grams. Multiplying this by 80 works out what 80 ounces is in grams

..... 2266.6 grams
(2)

(Total for Question 14 is 3 marks)



- 15 2.5 kg of onions and 2 kg of carrots cost a total of £2.36
3 kg of carrots cost £1.74

Stuart has £2

He wants to buy 4 kg of onions.

Does Stuart have enough money to buy 4 kg of onions?

You must show how you get your answer.

$$1.74 \div 3$$

Dividing the £1.74 cost of the 3kg of carrots by the 3kg works out that the cost of 1kg of carrots is £0.58

$$0.58 \times 2$$

Multiplying the £0.58 for 1kg of carrots by 2 works out that the cost of the 2kg of carrots is £1.16

$$2.36 - 1.16$$

Subtracting the £1.16 cost of the 2kg of carrots from the total of £2.36 leaves £1.20 for the cost of 2.5kg of onions

$$1.20 \div 2.5$$

Dividing the £1.20 cost of 2.5kg of onions by the 2.5kg works out that 1kg of onions costs £0.48

$$0.48 \times 4 = 1.92$$

Multiplying the £0.48 cost of 1kg of onions by the 4kg works out that 4kg of onions costs £1.92

Yes

The £2 Stuart has is enough as it is more than the £1.92 cost of 4kg of onions

(Total for Question 15 is 5 marks)

16 There are three different types of potato in a box.

The table gives the number of each type of potato.

Type of potato	Number of potatoes
Jersey Royal	90
Charlotte	105
Maris Piper	105

Salim draws this pie chart for the information in the table.

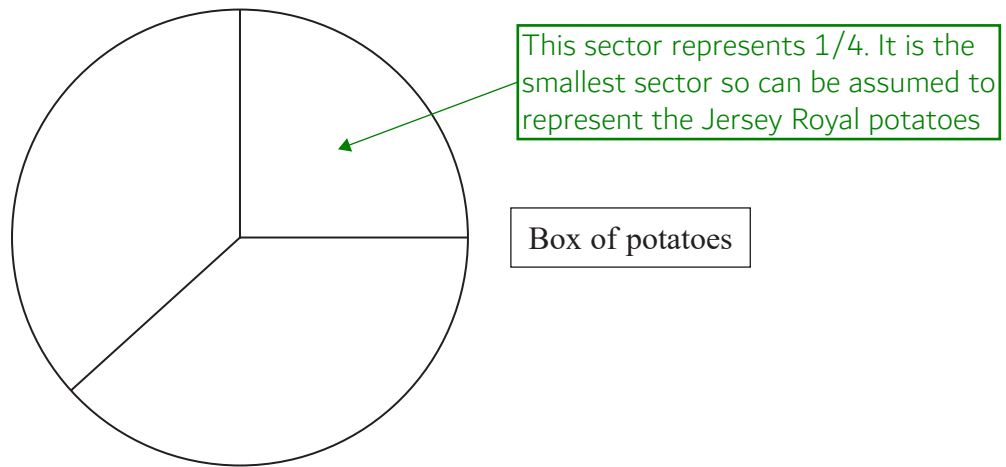

Write down two different things that are wrong or misleading with this pie chart.

1 No labels

So it is not clear which sector is for which type of potato

2 Wrong angles

Jersey Royal is not $\frac{1}{4}$ of the potatoes. $90 + 105 + 105 = 300$ and 90 is not $\frac{1}{4}$ of this

(Total for Question 16 is 2 marks)

17 (a) Write 87569 correct to 3 significant figures.

The 3rd significant figure is the 5. The 6 after this causes it to round up and then everything after the 3rd figure is ignored and set to 0

87600

(1)

(b) Work out $\frac{(3.2 + 3.7) \times 4.9}{5.3 - 2.8}$

Give your answer as a decimal.

Type it into the calculator exactly as it is above

13.524

(2)

(Total for Question 17 is 3 marks)

18

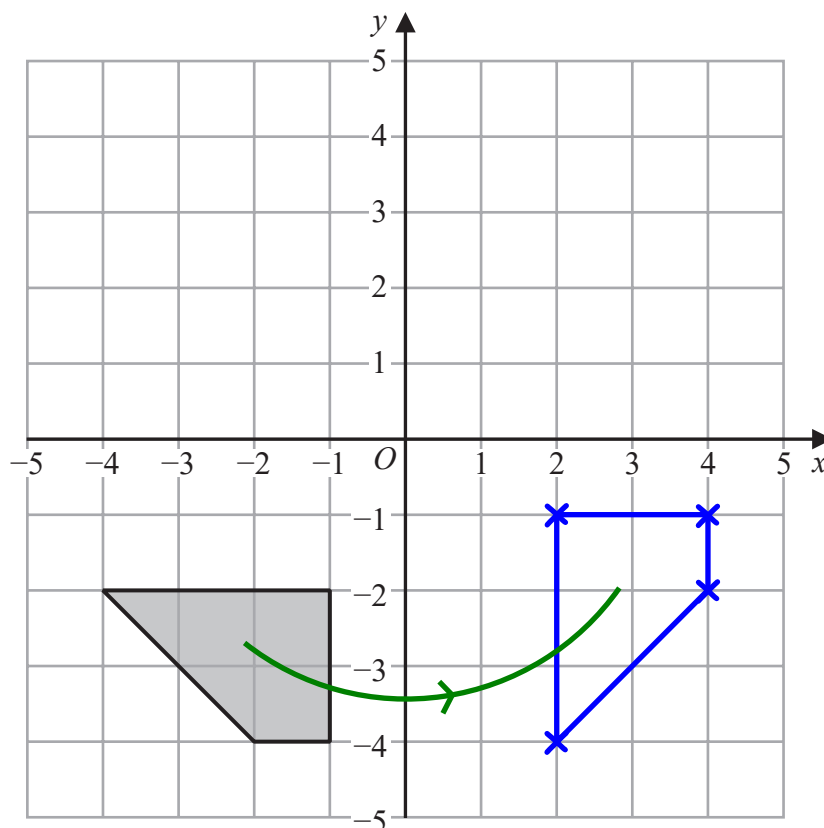

Rotate the shaded shape 90° anticlockwise about $(0,0)$

(Total for Question 18 is 2 marks)

Draw around the shape on tracing paper. Then put the needle of a compass in the tracing paper at $(0, 0)$ and rotate it 90° anticlockwise

- 19 Carly cycles to her friend's house.
She stays at her friend's house for a number of minutes.
Then she cycles home.

Here is the travel graph for her journey.

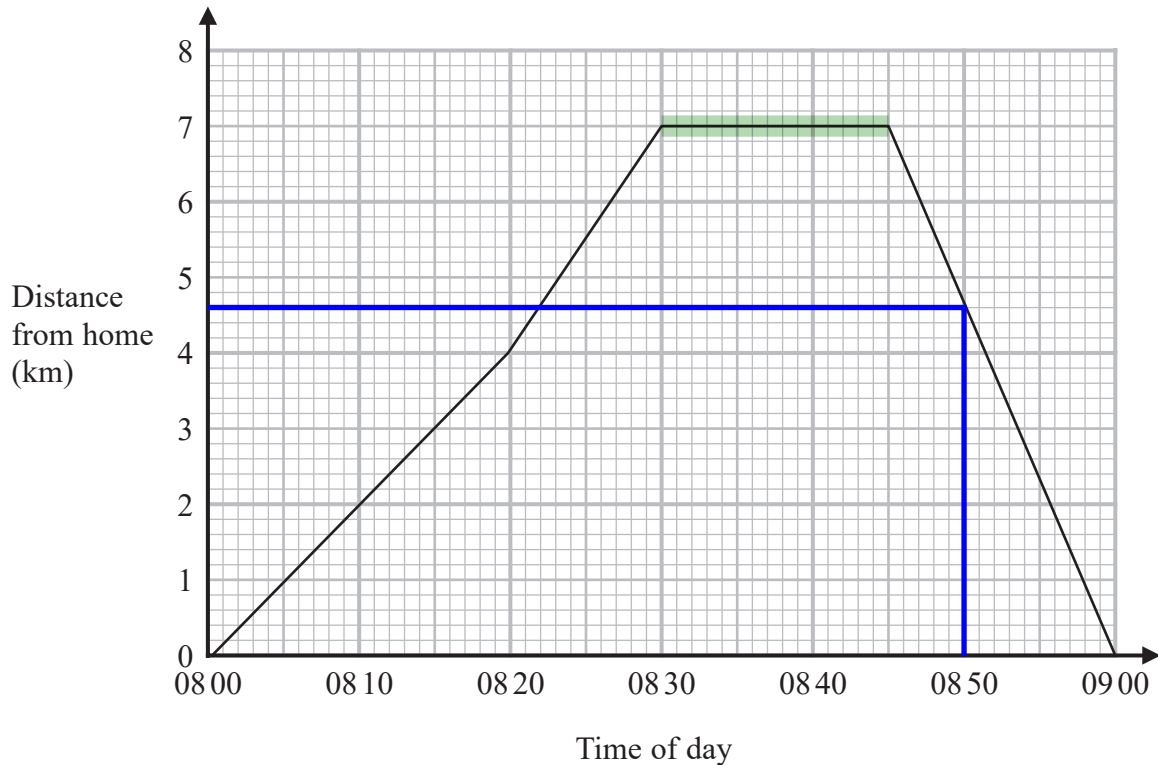

- (a) For how many minutes did Carly stay at her friend's house?

Her distance is not changing from 08 30 to 08 45.
This must be when she stays at her friend's house

..... 15 minutes
(1)

- (b) How far is Carly from her home at 08 50?

Reading up from 08 50 to the
line then across to the distance

..... 4.6 km
(1)

- (c) Work out Carly's speed, in km/h, for the first 20 minutes of her journey.

$4 \div 0.20$ ← km/h means to divide the distance travelled in kilometres by the time taken in hours.
The distance travelled in the first 20 minutes is 4 kilometres. Inputting the 20 minutes as a sexagesimal in the calculator and writing down what was put in the calculator

..... 12 km/h
(2)

(Total for Question 19 is 4 marks)

20 Here is a list of ingredients for making 10 scones.

Ingredients for 10 scones

80 g butter
350 g self-raising flour
30 g sugar
2 eggs

Martin has

100 g butter
1 kg self-raising flour
50 g sugar
4 eggs

Martin wants to make 25 scones.

He has not got enough of some of the ingredients.

Work out how much more of each of these ingredients he needs.

$25 \div 10$

Dividing the 25 scones he wants to make by the 10 scones the ingredients is for works out that 25 scones is 2.5 lots of the 10 scones, therefore all of the ingredients for 10 scones needs to be multiplied by 2.5

80×2.5

2.5 times the 80g of butter is 200g

$200 - 100 = 100$

Subtracting the 100g of butter he has from the 200g of butter he needs works out that he needs 100g more

$350 \times 2.5 = 875$

2.5 times the 350g of self-raising flour is 875g.
The 1kg he has is enough as 1kg is 1000g

30×2.5

2.5 times the 30g of sugar is 75g

$75 - 50 = 25$

Subtracting the 50g of sugar he has from the 75g of sugar he needs works out that he needs 25g more

2×2.5

2.5 times the 2 eggs is 5 eggs

$5 - 4 = 1$

Subtracting the 4 eggs he has from the 5 eggs he needs works out that he needs 1 more

100g butter, 25g sugar, 1 egg

(Total for Question 20 is 4 marks)

21 Make a the subject of the formula $p = 3a - 9$

$$p+9=3a \leftarrow \text{Adding 9 to both sides eliminates the } -9 \text{ on the right and gets the } a \text{ term on its own}$$

Dividing both sides by 3 eliminates the 3 on the right and gets a on its own

$$\frac{p+9}{3} = a$$

(Total for Question 21 is 2 marks)

22 Rob has been asked to divide 120 in the ratio 3:5

Here is his working.

$$120 \div 3 = 40 \qquad 120 \div 5 = 24$$

Rob's working is not correct.

Describe what Rob has done wrong.

Should divide by 8

There are 8 parts in total in the ratio as $3 + 5 = 8$. These 8 parts represent the 120 so dividing the 120 by 8 works out the value of 1 part. Then multiplying the value of 1 part by the 3 and by the 5 divides the 120 in the ratio

(Total for Question 22 is 1 mark)

- 23 200 students chose one language to study.
Each student chose one language from French or Spanish or German.

Of the 200 students,

- 90 are boys and the rest of the students are girls
- 70 chose Spanish
- 60 of the 104 students who chose French are boys
- 18 girls chose German.

Work out how many boys chose Spanish.

	F	S	G	
B	60		8	90
G			18	
	104	70	26	200

Completing a two-way table with the information given then continuing to fill it out until the number of boys who chose Spanish is worked out. B and G stands for boys and girls. F, S and G stands for French, Spanish and German. The totals are at the end of each row and column. If there is one missing number in a row or column, the other numbers in that row or column can be used to work out the missing number

$200 - 104 - 70 = 26$ students chose German in total.
 $26 - 18 = 8$ boys chose German.
 $90 - 60 - 8 = 22$ boys chose Spanish.
 There is no need to complete the whole table

22

(Total for Question 23 is 3 marks)

24 Karina has 4 tanks on her tractor.

Each tank is a cylinder with diameter 80 cm and height 160 cm.

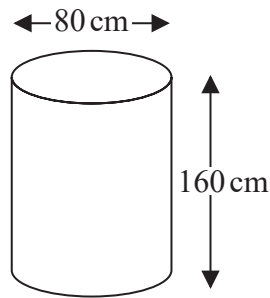

The 4 tanks are to be filled completely with a mixture of fertiliser and water.

The fertiliser has to be mixed with water in the ratio 1 : 100 by volume.

Karina has 32 litres of fertiliser.

1 litre = 1000 cm³

Has Karina enough fertiliser for the 4 tanks?

You must show how you get your answer.

$80 \div 2$ ← This works out that the radius of each tank is 40cm. The radius is half the diameter

$\pi \times 40^2 \times 160$ ← This works out the volume of one of the tanks. Volume of cylinder = $\pi \times \text{radius}^2 \times \text{height}$

$256000\pi \times 4$ ← Multiplying the volume of one of the tanks by 4 works out the volume of all 4 tanks

$1024000\pi \div 101$ ← This works out the volume of the fertiliser needed. $100 + 1 = 101$ so there are this many parts in total in the ratio. 101 parts represent the total volume of all the tanks. Dividing the volume of all 4 tanks by 101 works out the value of 1 part of the ratio, which represents the volume of fertiliser

$31851.3... \div 1000$ ← Dividing the volume of fertiliser in cm³ by 1000 converts it into litres as every 1000cm³ is 1 litre

31.8...

Yes ← The 31.8... litres Karina needs is less than the 32 litres Karina has

(Total for Question 24 is 4 marks)

25 Triangle ABC and triangle DEF are similar.

Similar means that they are the same shape but one is an enlargement of the other

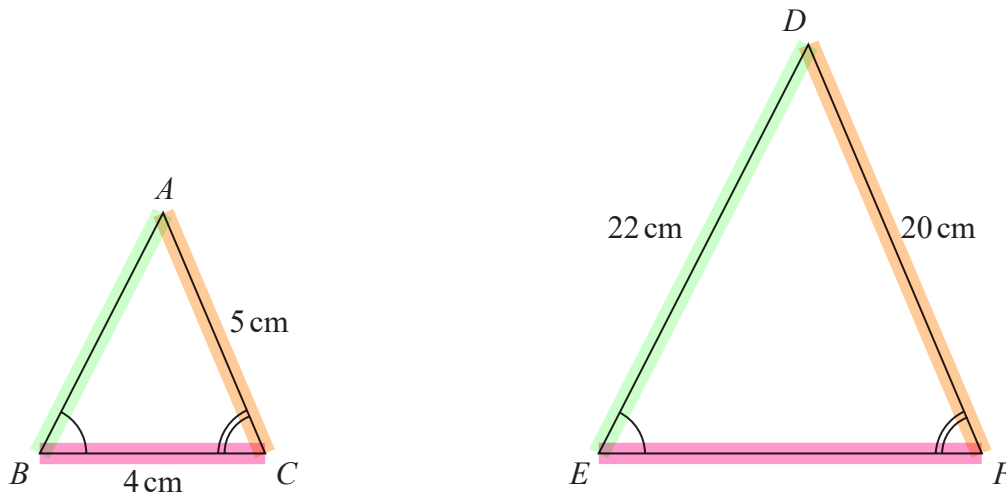

(a) Work out the length of EF .

$$20 \div 5 = 4$$

The sides in orange are the same side (as they are opposite the same angle) but the 20cm is the bigger version of the 5cm. Dividing the 20cm by the 5cm works out that the scale factor (what all the sides are multiplied by) is 4

$$4 \times 4$$

The sides in pink are the same side (as they are opposite the same angle) but EF is the bigger version of the 4cm. Multiplying the 4cm by the scale factor works out EF

$$\dots\dots\dots 16 \dots\dots\dots \text{cm}$$

(2)

(b) Work out the length of AB .

$$22 \div 4$$

The sides in green are the same side (as they are opposite the same angle) but the 22cm is the bigger version of AB . Dividing the 22cm by the scale factor works out AB

$$\dots\dots\dots 5.5 \dots\dots\dots \text{cm}$$

(2)

(Total for Question 25 is 4 marks)

26 One weekend the Keddie family is going to do a sports quiz and a music quiz.

The probability that the family will win the sports quiz is 0.3

The probability that the family will win the music quiz is 0.35

(a) Complete the probability tree diagram.

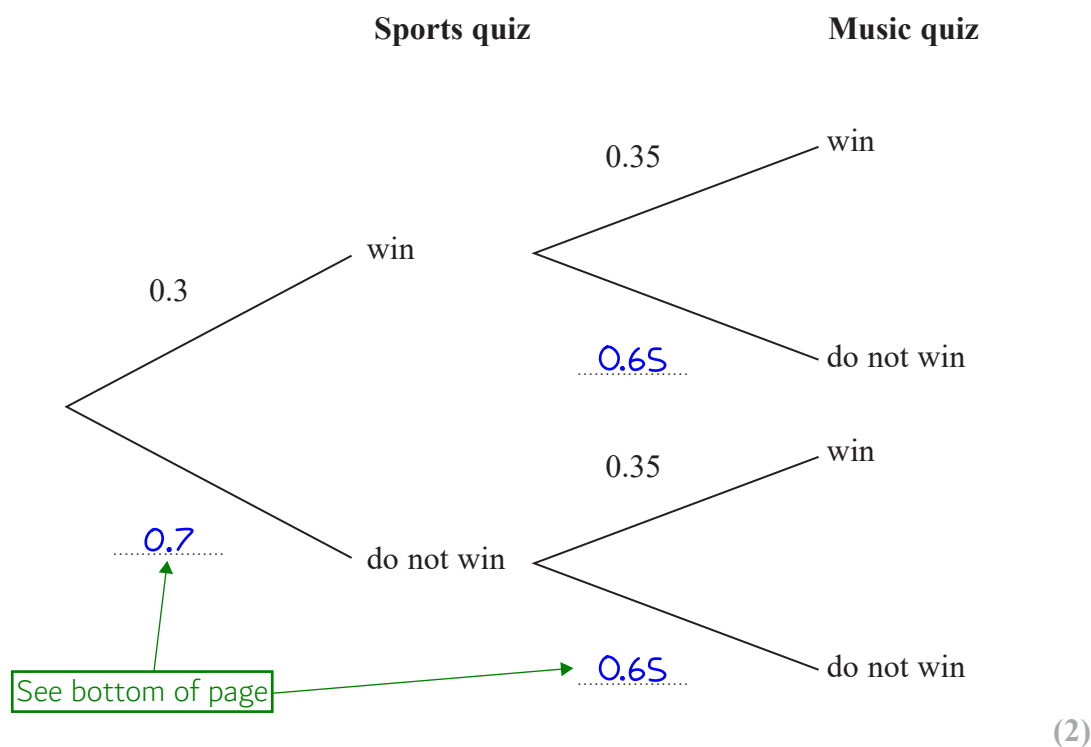

(b) Work out the probability that the Keddie family will win both the sports quiz and the music quiz.

0.3×0.35 ← Win AND win. AND means to multiply the probabilities

0.105

(2)

(Total for Question 26 is 4 marks)

It is certain to either win or not win so the probabilities need to add up to 1 as this is the probability of something which is certain. Subtracting the probabilities of winning from 1 leaves the probabilities of not winning. $1 - 0.3 = 0.7$. $1 - 0.35 = 0.65$

27 (a) Change 8000 cm^3 to m^3

$$8000 \div 100^3$$

There are 100cm in 1m. So dividing by 100 converts cm into m but as the unit is cubed the cm^3 must be divided by 100^3

$$\dots\dots\dots 0.008 \dots\dots\dots \text{m}^3$$

(1)

(b) Change a speed of 180 km per hour to metres per second.

Metres per second means to divide the distance in metres by the time in seconds

$$180 \times 1000 = 180000$$

There are 1000m in 1km so multiplying the distance in km by 1000 converts it into metres

$$1 \times 60 \times 60 = 3600$$

There are 60 minutes in an hour so multiplying the 1 hour by 60 converts it into minutes. There are 60 seconds in a minute so multiplying by 60 again converts it into seconds

$$180000 \div 3600$$

Dividing the distance in metres by the time in seconds gives metres per second

$$\dots\dots\dots 50 \dots\dots\dots \text{metres per second}$$

(3)

(Total for Question 27 is 4 marks)

28 There are 30 women and 20 men at a gym.

The mean height of all 50 people is 167.6 cm

The mean height of the 20 men is 182 cm

Work out the mean height of the 30 women.

$$m^t_n$$

Mean = total \div number, where total is the total height of all the people and number is the number of people. Writing this as a formula triangle

$$167.6 \times 50 = 8380$$

From the formula triangle, total = mean \times number. Multiplying the mean of all the people by the 50 people works out that the total height of all the people is 8380cm

$$182 \times 20 = 3640$$

From the formula triangle, total = mean \times number. Multiplying the mean of all the men by the 20 men works out that the total height of all the men is 3640cm

$$8380 - 3640$$

Subtracting the total height of the men from the total height of all the people works out that the total height of the women is 4740cm

$$4740 \div 30$$

Mean = total \div number, so dividing the total height of the women by the number of women

$$\dots\dots\dots 158 \dots\dots\dots \text{cm}$$

(Total for Question 28 is 3 marks)

29 (a) Write 6.75×10^{-4} as an ordinary number.

$\times 10^{-4}$ means to divide by 10 4 times. So moving the decimal point 4 times to the left

0.000675

(1)

(b) Work out $\frac{2.56 \times 10^6 \times 4.12 \times 10^{-3}}{1.6 \times 10^{-2}}$

Give your answer in standard form.

Put it into the calculator exactly as it is above

659200

The answer is an ordinary number. It must be divided by 10 5 times to get a decimal between 1 and 10 which must be multiplied by 10^5 to keep it equal

6.592 $\times 10^5$

(2)

(Total for Question 29 is 3 marks)

$$30 \quad \mathbf{a} = \begin{pmatrix} 2 \\ 3 \end{pmatrix} \quad \mathbf{b} = \begin{pmatrix} -1 \\ 2 \end{pmatrix} \quad \mathbf{c} = \begin{pmatrix} 4 \\ 1 \end{pmatrix}$$

Column vectors are in the form $\begin{pmatrix} x \\ y \end{pmatrix}$

(a) Work out $\mathbf{a} + \mathbf{b}$ as a column vector

(i) $\mathbf{a} + \mathbf{b}$

$$\begin{matrix} 2+(-1) \\ 3+2 \end{matrix}$$

← Adding the x-components and the y-components separately

$$\begin{pmatrix} 1 \\ 5 \end{pmatrix}$$

(1)

(ii) $2\mathbf{a} - \mathbf{c}$

$$2 \times 2 - 4$$

← Doing 2 multiplied by the x-component of \mathbf{a} subtract the x-component of \mathbf{c} gives the x-component

$$2 \times 3 - 1$$

← Doing 2 multiplied by the y-component of \mathbf{a} subtract the y-component of \mathbf{c} gives the y-component

$$\begin{pmatrix} 0 \\ 5 \end{pmatrix}$$

(2)

The vector \mathbf{d} is drawn on the grid.

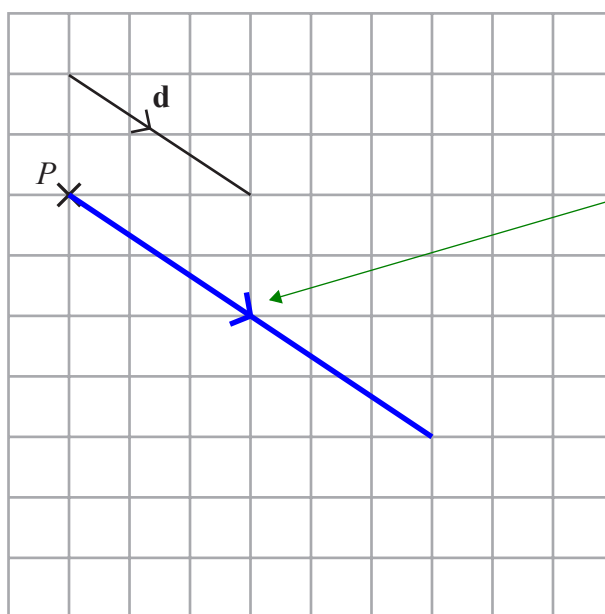

Twice as long as vector \mathbf{d} in the same direction

(b) From the point P , draw the vector $2\mathbf{d}$

(1)

(Total for Question 30 is 4 marks)

TOTAL FOR PAPER IS 80 MARKS