

Write your name here

Surname

Other names

Pearson Edexcel
Level 1/Level 2 GCSE (9-1)

Centre Number

--	--	--	--	--

Candidate Number

--	--	--	--

Mathematics

Paper 2 (Calculator)

Foundation Tier

Thursday 7 June 2018 – Morning
Time: 1 hour 30 minutes

Paper Reference

1MA1/2F

You must have: Ruler graduated in centimetres and millimetres, protractor, pair of compasses, pen, HB pencil, eraser, calculator. Tracing paper may be used.

Total Marks



Instructions

- Use **black** ink or ball-point pen.
- **Fill in the boxes** at the top of this page with your name, centre number and candidate number.
- Answer **all** questions.
- Answer the questions in the spaces provided – *there may be more space than you need.*
- You must **show all your working.**
- Diagrams are **NOT** accurately drawn, unless otherwise indicated.
- **Calculators may be used.**
- If your calculator does not have a π button, take the value of π to be 3.142 unless the question instructs otherwise.

Information

- The total mark for this paper is 80
- The marks for **each** question are shown in brackets – *use this as a guide as to how much time to spend on each question.*

Advice

- Read each question carefully before you start to answer it.
- Keep an eye on the time.
- Try to answer every question.
- Check your answers if you have time at the end.

Turn over ►

P48863A

©2018 Pearson Education Ltd.

6/7/7/7/8/7/1/c2/1/



Pearson

Answer ALL questions.

Write your answers in the spaces provided.

You must write down all the stages in your working.

1 Write $\frac{4}{50}$ as a percentage.

.....%

(Total for Question 1 is 1 mark)

2 Write 1.59 correct to 1 decimal place.

.....

(Total for Question 2 is 1 mark)

3 Work out the value of 3^5

.....

(Total for Question 3 is 1 mark)

4 Write down a 6 digit number that has 4 as its thousands digit.
You can only use the digit 4 once.

.....

(Total for Question 4 is 1 mark)

DO NOT WRITE IN THIS AREA

DO NOT WRITE IN THIS AREA

DO NOT WRITE IN THIS AREA



DO NOT WRITE IN THIS AREA

DO NOT WRITE IN THIS AREA

DO NOT WRITE IN THIS AREA

5 (a) Change 35 cm to mm.

..... mm
(1)

(b) Change 7700 millilitres to litres.

..... litres
(1)

(c) Change 0.32 kilograms to grams.

..... grams
(1)

(Total for Question 5 is 3 marks)

6 Margaret is thinking of a number.
She says,

“My number is odd. It is a factor of 36 and a multiple of 3”

There are two possible numbers Margaret can be thinking of.

Write down these two numbers.

.....
(Total for Question 6 is 3 marks)



- 7 Mohsin, Yusuf and Luke are going to play a game.
At the end of the game, one of them will be in First place, one of them will be in Second place and one of them will be in Third place.

Use the table below to list all the possible outcomes of the game.

First place	Second place	Third place

(Total for Question 7 is 2 marks)

DO NOT WRITE IN THIS AREA

DO NOT WRITE IN THIS AREA

DO NOT WRITE IN THIS AREA



DO NOT WRITE IN THIS AREA

DO NOT WRITE IN THIS AREA

DO NOT WRITE IN THIS AREA

8 Neil buys 30 pens, 30 pencils, 30 rulers and 30 pencil cases.

Price list	
pens	6 for 82p
pencils	15 for 45p
rulers	10 for £1.25
pencil cases	37p each

What is the total amount of money Neil spends?

£.....

(Total for Question 8 is 5 marks)



9 Emily drives 186 miles in 3 hours.

(a) What is her average speed?

..... mph
(2)

Sarah drives at an average speed of 58 mph for 4 hours.

(b) How many miles does Sarah drive?

..... miles
(2)

(Total for Question 9 is 4 marks)

10 (a) Write down all the prime numbers between 20 and 30

.....
(2)

Catherine says,

“2 is the only even prime number.”

(b) Is Catherine right?

You must give a reason for your answer.

.....
.....
(1)

(Total for Question 10 is 3 marks)



DO NOT WRITE IN THIS AREA

DO NOT WRITE IN THIS AREA

DO NOT WRITE IN THIS AREA

11 (a) Solve $x + x + x = 51$

$x = \dots\dots\dots$
(1)

(b) Solve $\frac{y}{4} = 3$

$y = \dots\dots\dots$
(1)

(c) Solve $2f + 7 = 18$

$f = \dots\dots\dots$
(1)

(Total for Question 11 is 3 marks)



12 A group of football fans were asked what their half time snack was.

The table below gives information about their answers.

Snack	Number of fans
burger	11
pie	17
hot dog	8

Draw an accurate pie chart for this information.

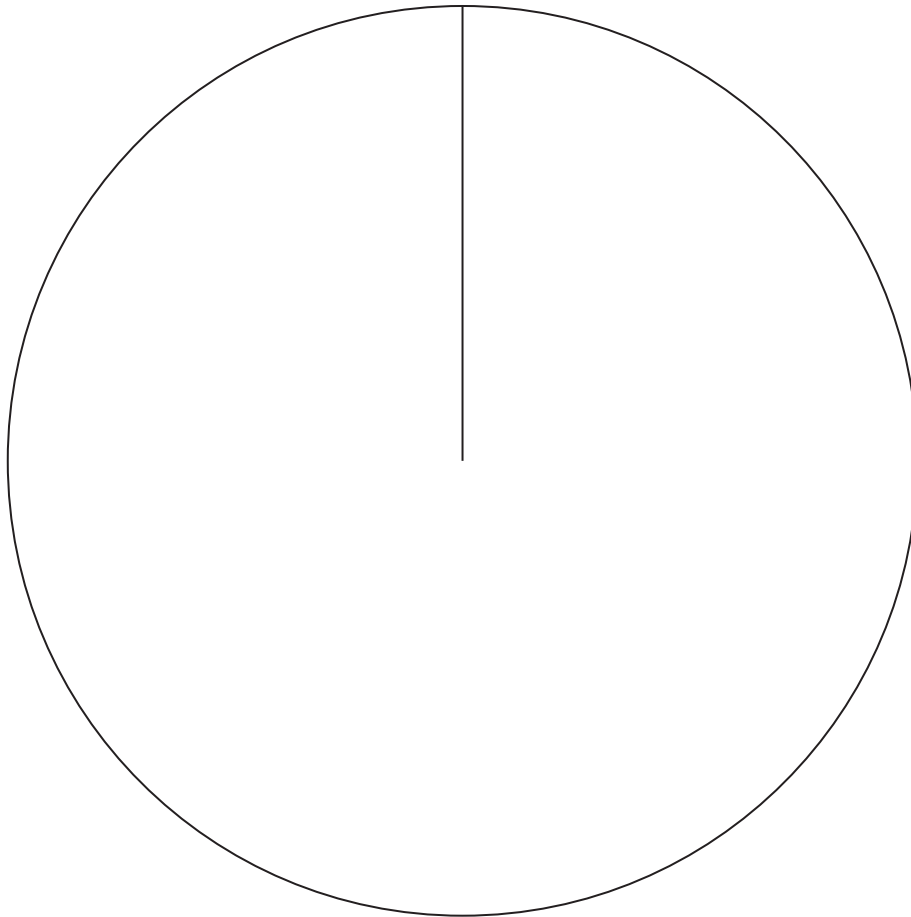

(Total for Question 12 is 3 marks)



DO NOT WRITE IN THIS AREA

DO NOT WRITE IN THIS AREA

DO NOT WRITE IN THIS AREA

13 A scout group has a raffle to raise money for charity.
There is 1 prize to be won in the raffle.

Laura buys 12 raffle tickets.
A total of 350 raffle tickets are sold.

Find the probability that Laura does **not** win the prize.

.....
(Total for Question 13 is 2 marks)



14 Each worker in a factory is either left-handed or right-handed.

22 of the 45 workers are male.

16 of the 34 right-handed workers are female.

Complete the frequency tree for this information.

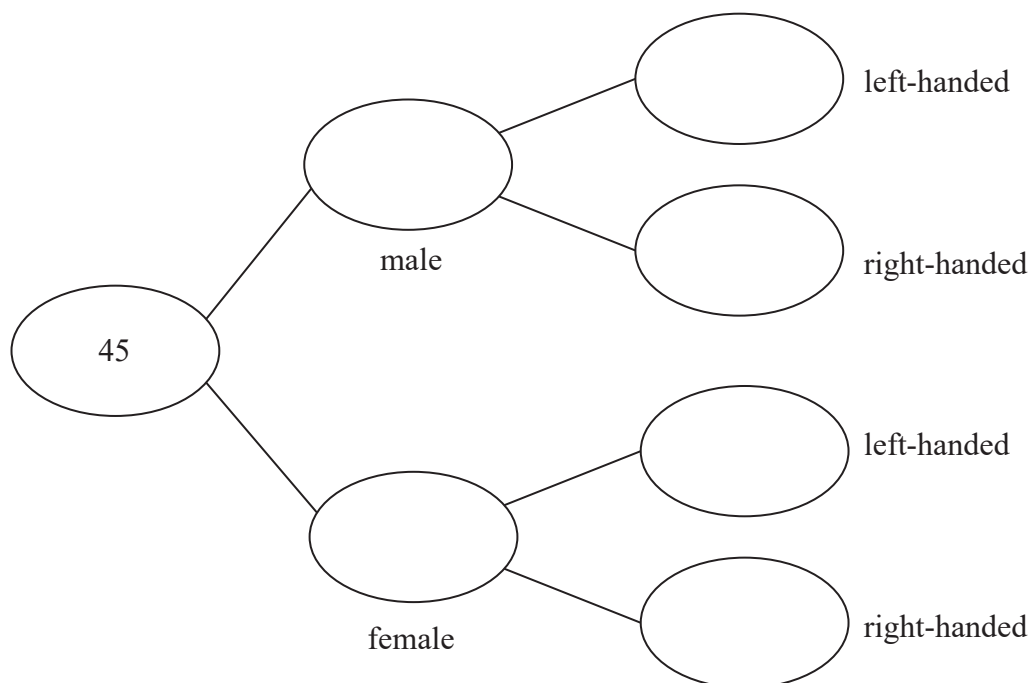

(Total for Question 14 is 3 marks)



DO NOT WRITE IN THIS AREA

DO NOT WRITE IN THIS AREA

DO NOT WRITE IN THIS AREA

15 Mary needs to work out the size of angle x in this diagram.

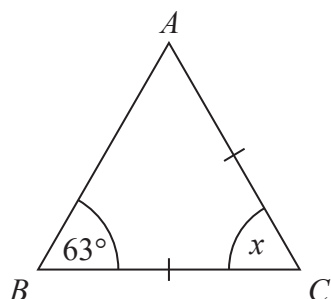

She writes

$x = 63^\circ$ because base angles of an isosceles triangle are equal.

Mary is wrong.

(a) Explain why.

(1)

William needs to work out the size of angle y in this diagram.

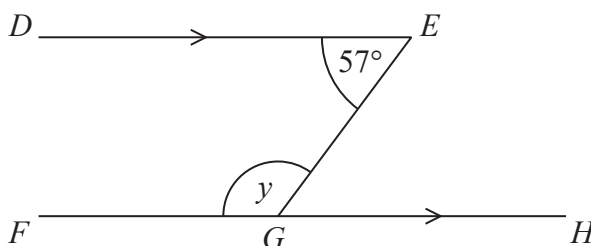

William writes

Working	Reason
angle $EGH = 57^\circ$	because corresponding angles are equal
$y = 180^\circ - 57^\circ$ $y = 123^\circ$	because angles on a straight line add up to 180°

One of William's reasons is wrong.

(b) Write down the correct reason.

(1)

(Total for Question 15 is 2 marks)



P 4 8 8 6 3 A 0 1 1 2 4

16 Marla buys some bags of buttons.

There are 19 buttons or 20 buttons or 21 buttons or 22 buttons in each bag.

The table gives some information about the number of buttons in each bag.

Number of buttons	Frequency
19
20	7
21	3
22	1

The total number of buttons is 320

Complete the table.

(Total for Question 16 is 3 marks)



DO NOT WRITE IN THIS AREA

DO NOT WRITE IN THIS AREA

DO NOT WRITE IN THIS AREA

17 Here is the list of ingredients for making 30 biscuits.

Ingredients for 30 biscuits 225 g butter 110 g caster sugar 275 g plain flour 75 g chocolate chips
--

Lucas has the following ingredients.

- 900 g butter
- 1000 g caster sugar
- 1000 g plain flour
- 225 g chocolate chips

What is the greatest number of biscuits Lucas can make?
You must show your working.

.....
(Total for Question 17 is 3 marks)



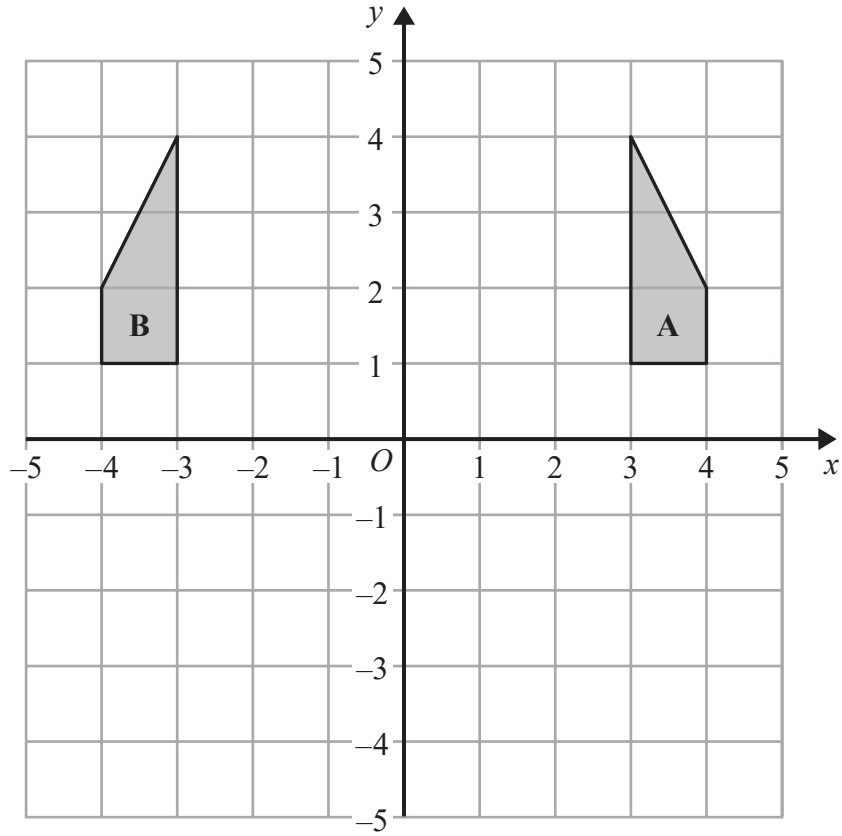

Describe fully the single transformation that maps shape A onto shape B.

.....

.....

(Total for Question 18 is 2 marks)

DO NOT WRITE IN THIS AREA

DO NOT WRITE IN THIS AREA

DO NOT WRITE IN THIS AREA



DO NOT WRITE IN THIS AREA

DO NOT WRITE IN THIS AREA

DO NOT WRITE IN THIS AREA

19 A farmer has a field in the shape of a semicircle of diameter 50 m.

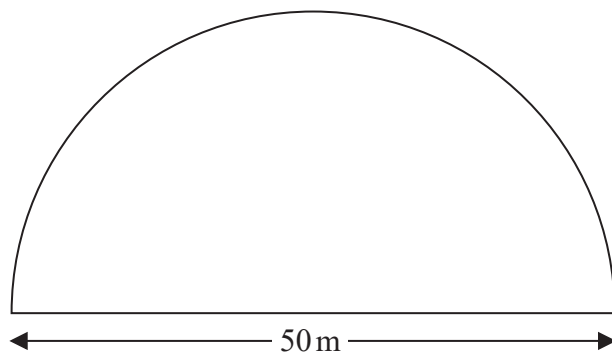

The farmer asks Jim to build a fence around the edge of the field.
Jim tells him how much it will cost.

Total cost = £29.86 per metre of fence plus £180 for each day's work

Jim takes three days to build the fence.

Work out the total cost.

£.....

(Total for Question 19 is 5 marks)



20 (a) Simplify $m^3 \times m^4$

.....
(1)

(b) Simplify $(5np^3)^3$

.....
(2)

(c) Simplify $\frac{32q^9r^4}{4q^3r}$

.....
(2)

(Total for Question 20 is 5 marks)

DO NOT WRITE IN THIS AREA

DO NOT WRITE IN THIS AREA

DO NOT WRITE IN THIS AREA



DO NOT WRITE IN THIS AREA

DO NOT WRITE IN THIS AREA

DO NOT WRITE IN THIS AREA

21 (a) Find the lowest common multiple (LCM) of 40 and 56

.....
(2)

$$A = 2^3 \times 3 \times 5 \qquad B = 2^2 \times 3 \times 5^2$$

(b) Write down the highest common factor (HCF) of A and B .

.....
(1)

(Total for Question 21 is 3 marks)



22 The line **L** is shown on the grid.

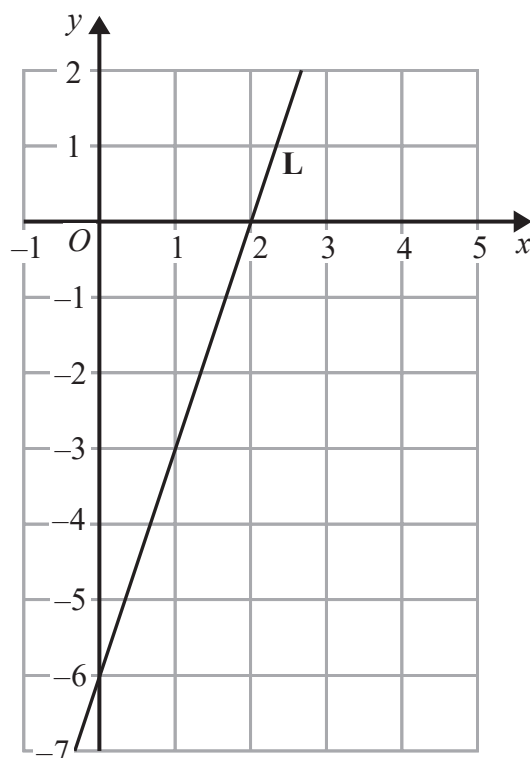

Find an equation for **L**.

(Total for Question 22 is 3 marks)



DO NOT WRITE IN THIS AREA

DO NOT WRITE IN THIS AREA

DO NOT WRITE IN THIS AREA

23 Raya buys a van for £8500 plus VAT at 20%

Raya pays a deposit for the van.

She then pays the rest of the cost in 12 equal payments of £531.25 each month.

Find the ratio of the deposit Raya pays to the total of the 12 equal payments.

Give your answer in its simplest form.

.....
(Total for Question 23 is 5 marks)



24 (a) Complete the table of values for $y = x^2 - x - 6$

x	-3	-2	-1	0	1	2	3
y	6			-6			

(2)

(b) On the grid, draw the graph of $y = x^2 - x - 6$ for values of x from -3 to 3

(2)

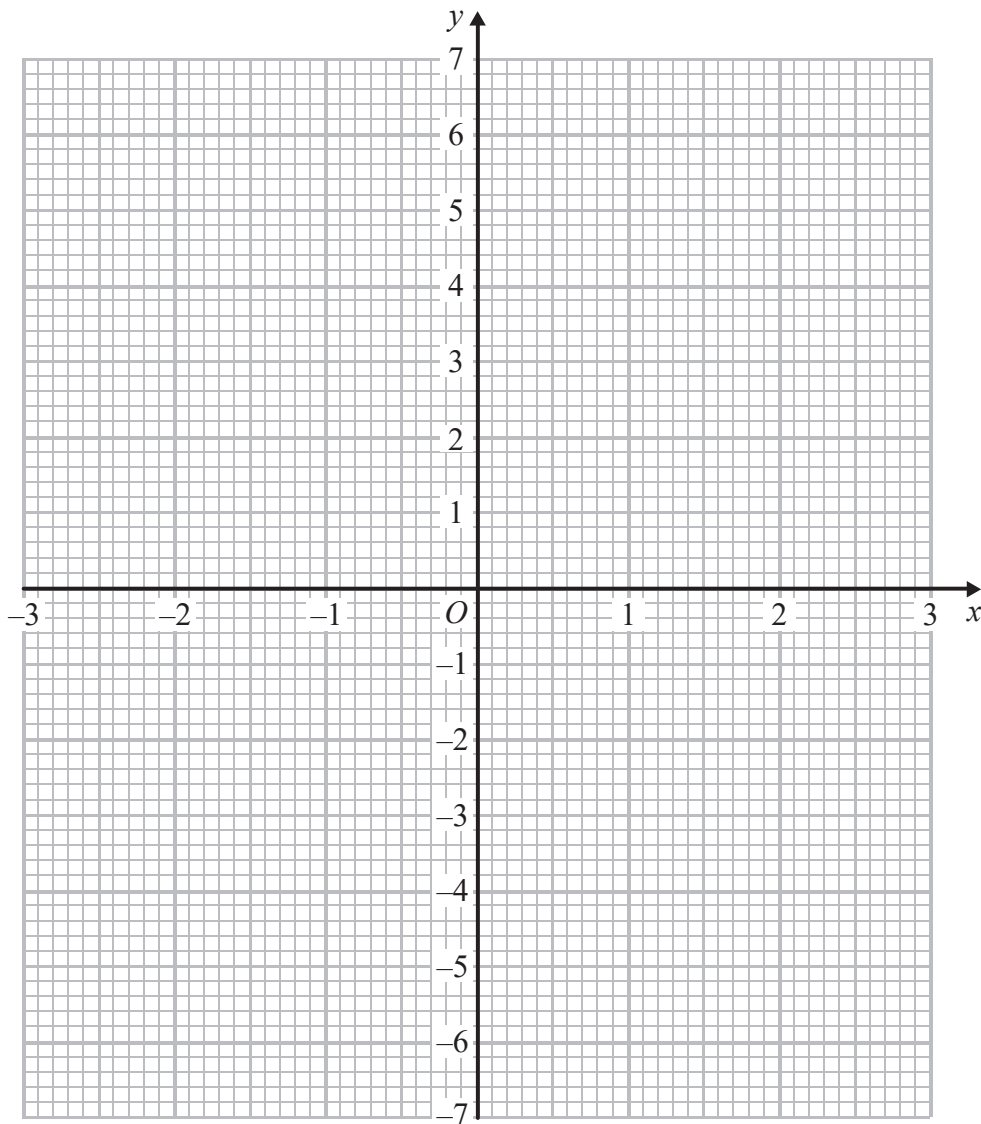

(c) Use your graph to find estimates of the solutions to the equation $x^2 - x - 6 = -2$

.....
(2)

(Total for Question 24 is 6 marks)

25 A force of 70 newtons acts on an area of 20 cm^2

The force is increased by 10 newtons.

The area is increased by 10 cm^2

$$\text{pressure} = \frac{\text{force}}{\text{area}}$$

Helen says,

“The pressure decreases by less than 20%”

Is Helen correct?

You must show how you get your answer.

(Total for Question 25 is 3 marks)

DO NOT WRITE IN THIS AREA

DO NOT WRITE IN THIS AREA

DO NOT WRITE IN THIS AREA



P 4 8 8 6 3 A 0 2 1 2 4

26 Here is a triangular prism.

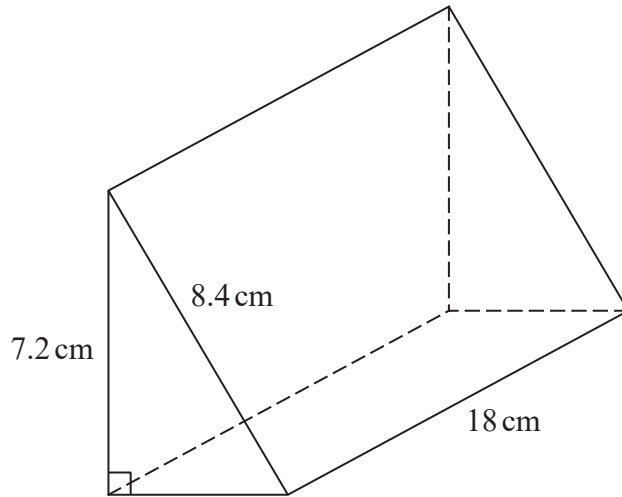

Work out the volume of the prism.
Give your answer correct to 3 significant figures.

..... cm³

(Total for Question 26 is 5 marks)

TOTAL FOR PAPER IS 80 MARKS

DO NOT WRITE IN THIS AREA

DO NOT WRITE IN THIS AREA

DO NOT WRITE IN THIS AREA



DO NOT WRITE IN THIS AREA

DO NOT WRITE IN THIS AREA

DO NOT WRITE IN THIS AREA

BLANK PAGE



P 4 8 8 6 3 A 0 2 3 2 4

DO NOT WRITE IN THIS AREA

DO NOT WRITE IN THIS AREA

DO NOT WRITE IN THIS AREA

BLANK PAGE

