

Please check the examination details below before entering your candidate information

Candidate surname

Other names

Centre Number

Candidate Number

Pearson Edexcel
Level 1/Level 2 GCSE (9–1)

--	--	--	--	--

--	--	--	--	--

Tuesday 19 May 2020

Morning (Time: 1 hour 30 minutes)

Paper Reference **1MA1/1H**

Mathematics

Paper 1 (Non-Calculator)

Higher Tier

You must have: Ruler graduated in centimetres and millimetres, protractor, pair of compasses, pen, HB pencil, eraser.
Tracing paper may be used.

Total Marks

Instructions

- Use **black** ink or ball-point pen.
- **Fill in the boxes** at the top of this page with your name, centre number and candidate number.
- Answer **all** questions.
- Answer the questions in the spaces provided
– *there may be more space than you need.*
- You must **show all your working**.
- Diagrams are **NOT** accurately drawn, unless otherwise indicated.
- **Calculators may not be used.**



Information

- The total mark for this paper is 80
- The marks for **each** question are shown in brackets
– *use this as a guide as to how much time to spend on each question.*

Advice

- Read each question carefully before you start to answer it.
- Keep an eye on the time.
- Try to answer every question.
- Check your answers if you have time at the end.

Turn over ►

P62277RA

©2020 Pearson Education Ltd.

1/1/1/1/

.CG Maths.
Worked Solutions



Pearson

Please note that these worked solutions have neither been provided nor approved by Pearson Education and may not necessarily constitute the only possible solutions. Please refer to the original mark schemes for full guidance.

Any writing in blue should be written in the exam.

Anything written in green in a rectangle doesn't have to be written in the exam.

If you find any mistakes or have any requests or suggestions, please send an email to curtis@cgmaths.co.uk

Answer ALL questions.

Write your answers in the spaces provided.

You must write down all the stages in your working.

1 The first five terms of an arithmetic sequence are

1 4 7 10 13

Write down an expression, in terms of n , for the n th term of this sequence.

The sequence increases by 3 each term so it must involve $3n$. The 0th term (the one before the first term) would be -2 so it must be $3n - 2$

$3n - 2$

(Total for Question 1 is 2 marks)

2 Show that

$$2\frac{1}{3} \times 3\frac{3}{4} = 8\frac{3}{4}$$

$$\frac{7}{3} \times \frac{15}{4}$$

Converting the mixed numbers on the left into improper fractions by multiplying the whole number by the denominator then adding the result to the numerator. $2 \times 3 = 6$. $1 + 6 = 7$. $3 \times 4 = 12$. $3 + 12 = 15$.

$$\frac{7}{1} \times \frac{5}{4}$$

Dividing both the 3 on the denominator and the 15 on the numerator by 3 to simplify the multiplication

$$\frac{35}{4}$$

Multiplying the fractions by multiplying the numerators and multiplying the denominators

$$8\frac{3}{4}$$

Converting to a mixed number by dividing the numerator by the denominator to get the whole number and leaving the remainder in the fraction

(Total for Question 2 is 3 marks)

DO NOT WRITE IN THIS AREA

DO NOT WRITE IN THIS AREA

DO NOT WRITE IN THIS AREA

DO NOT WRITE IN THIS AREA

DO NOT WRITE IN THIS AREA

DO NOT WRITE IN THIS AREA

3 The diagram shows four graphs.

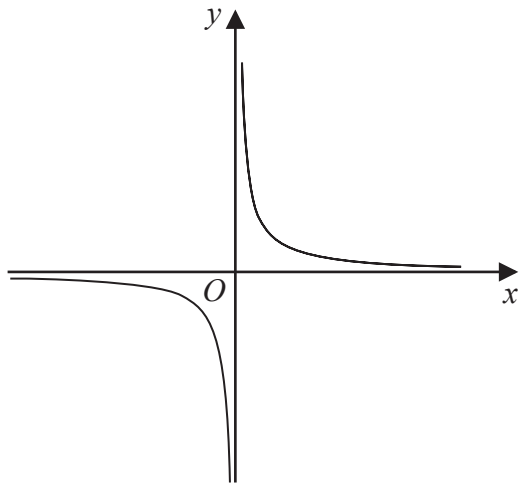

Graph A

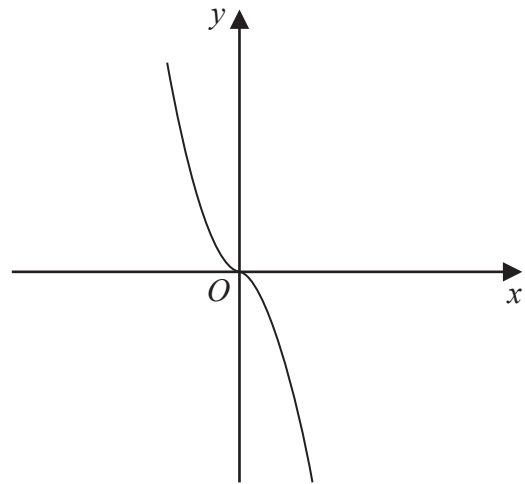

Graph B

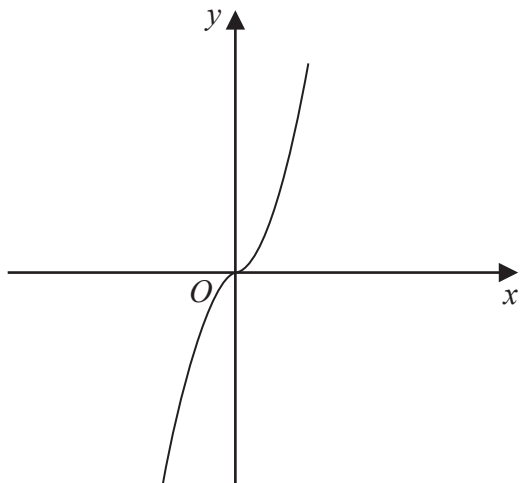

Graph C

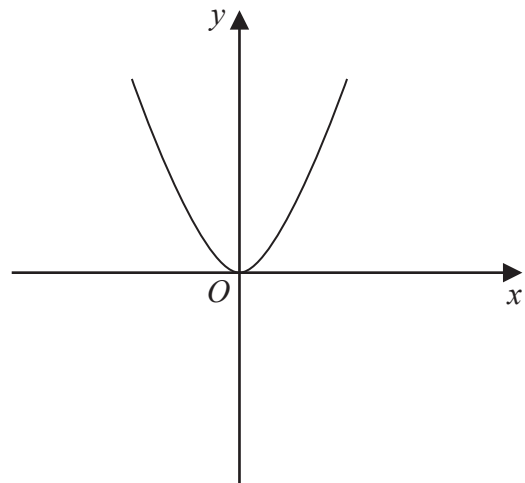

Graph D

Each of the equations in the table is the equation of one of the graphs.

Complete the table.

Doing a table of values for x values from -1 to 1 for each equation can work out which graph is which equation

x	-1	0	1	Equation	Letter of graph	
y	1	0	-1	$y = -x^3$	B	← Is decreasing so must be B
y	-1	0	1	$y = x^3$	C	← Is increasing so must be C
y	1	0	1	$y = x^2$	D	← Decreases then increases so must be D
y	-1	-	1	$y = \frac{1}{x}$	A	← No value when $x = 0$ so must be A

Cannot divide by 0

(Total for Question 3 is 2 marks)

4 The diagram shows four triangles.

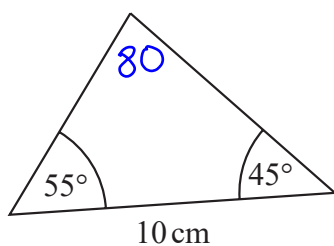

Triangle A

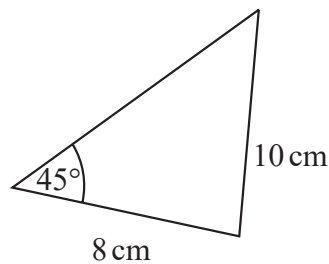

Triangle B

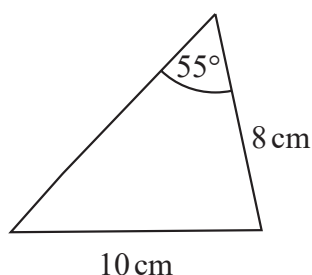

Triangle C

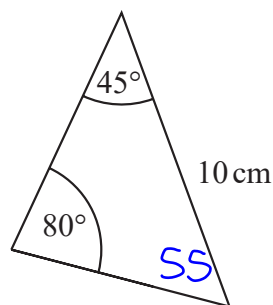

Triangle D

Two of these triangles are congruent. ← Same shape and size

Write down the letters of these two triangles.

It can't be B or C as the 10 cm is opposite a different angle to the others

A and D

(Total for Question 4 is 1 mark)

5 Sean pays £10 for 24 chocolate bars.

He sells all 24 chocolate bars for 50p each.

Work out Sean's percentage profit.

$24 \div 2$ ← 50p is half of £1. So halving the 24 bars works out that the income from selling them is £12

$12 - 10$ ← Subtracting the original £10 paid from the £12 income works out that the profit is £2

$\frac{2}{10}$ ← Putting the £2 profit over the £10 paid expresses the profit as a fraction

$\frac{20}{100}$ ← Multiplying both the numerator and denominator by 10 gets 100 as the denominator

Percentage is out of 100 so $20/100$ is 20%

20 %

(Total for Question 5 is 3 marks)

DO NOT WRITE IN THIS AREA

DO NOT WRITE IN THIS AREA

DO NOT WRITE IN THIS AREA

6 ADC is a triangle.

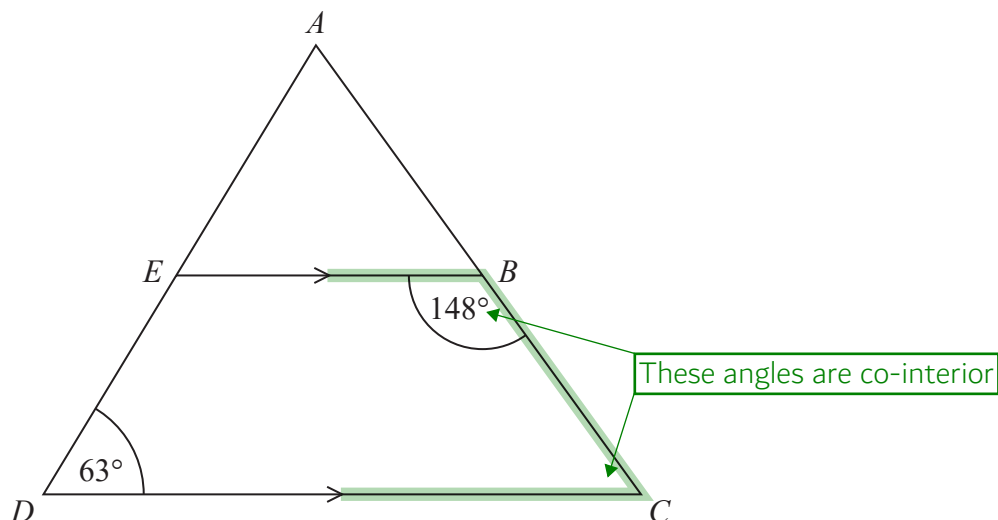

AED and ABC are straight lines.
 EB is parallel to DC .

Angle $EBC = 148^\circ$
Angle $ADC = 63^\circ$

Work out the size of angle EAB .
You must give a reason for each stage of your working.

Angle $BCD = 180^\circ - 148^\circ = 32^\circ$ as co-interior angles add up to 180°

Subtracting angle EBC from 180° leaves angle BCD

Angle $EAB = 180^\circ - 63^\circ - 32^\circ = 85^\circ$ as angles in a triangle add up to 180°

Subtracting angle ADC and angle BCD from the 180° in triangle ADC leaves angle EAB

(Total for Question 6 is 5 marks)

- 7 The table shows information about the heights, in cm, of a group of Year 9 girls.

least height	150 cm
median	165 cm
greatest height	170 cm

This stem and leaf diagram shows information about the heights, in cm, of a group of 15 Year 9 boys.

15	8 9 9
16	4 5 7 7 8
17	0 3 4 4 7
18	0 2

Key: 15 | 8 represents 158 cm

Compare the distribution of the heights of the girls with the distribution of the heights of the boys.

The 168 median for boys is higher than the 165 median for girls

$(15 + 1)/2 = 8$ so the 8th value is the median for the boys. They are arranged in order in the stem and leaf diagram so counting to the 8th value from the top left finds the median

The 24 range for boys is higher than the 20 range for girls

The greatest value for the boys was 182 and the least was 158. Range for the boys = $182 - 158 = 24$. Range for the girls = $170 - 150 = 20$

(Total for Question 7 is 3 marks)

DO NOT WRITE IN THIS AREA

DO NOT WRITE IN THIS AREA

DO NOT WRITE IN THIS AREA

8 The diagram shows a prism placed on a horizontal floor.

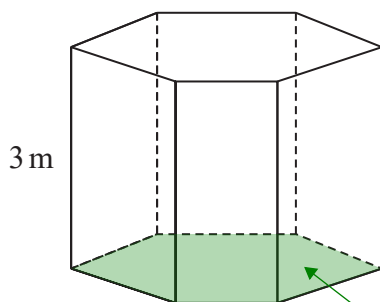

$$\text{pressure} = \frac{\text{force}}{\text{area}}$$

The prism has height 3 m
 The volume of the prism is 18 m^3

The pressure on the floor due to the prism is 75 newtons/m^2

Work out the force exerted by the prism on the floor.

$$18 \div 3 \leftarrow \begin{array}{l} \text{Volume of prism} = \text{cross sectional area} \times \text{length.} \\ \text{Cross sectional area} = \text{volume of prism} \div \text{length.} \\ \text{So the cross sectional area in contact with the floor is } 6 \text{ m}^2 \end{array}$$

$$75 = \frac{F}{6} \leftarrow \text{Substituting the } 75 \text{ newtons/m}^2 \text{ pressure and the } 6 \text{ m}^2 \text{ area into the formula. Let } F \text{ be the force}$$

$$\begin{array}{r} 75 \\ \times 6 \\ \hline 450 \\ \text{\scriptsize 3} \end{array} \leftarrow \text{Multiplying both sides by 6 gets the force on its own}$$

.....450..... newtons

(Total for Question 8 is 3 marks)

9 Write these numbers in order of size.
 Start with the smallest number.

6.72×10^5 67.2×10^{-4} 672×10^4 0.000672
 672000 0.00672 6720000

Writing the numbers as ordinary numbers. $\times 10^n$ means to multiply by 10 n times. $\times 10^{-n}$ means to divide by 10 n times

0.000672 67.2×10^{-4} 6.72×10^5 672×10^4

(Total for Question 9 is 2 marks)

10 Given that $\frac{a}{b} = \frac{2}{5}$ and $\frac{b}{c} = \frac{3}{4}$

find $a:b:c$

a	b	c
2	5	
	3	4

a could be 2 while b could be 5. b could be 3 while c could be 4. Writing these as ratios in columns

b is in common to both ratios and a common multiple of 5 and 3 is 15. Multiplying both sides of the first ratio by 3 and both sides of the second ratio by 5 makes it so that the ratios can be combined

6:15:20

(Total for Question 10 is 3 marks)

DO NOT WRITE IN THIS AREA

DO NOT WRITE IN THIS AREA

DO NOT WRITE IN THIS AREA

11 (a) Find the value of $\sqrt[4]{81 \times 10^8}$

This can be split into $\sqrt[4]{81} \times \sqrt[4]{10^8}$. The fourth root is the square root of the square root. $\sqrt{81} = 9$. $\sqrt{9} = 3$. The fourth root is the same as raising to the power of $1/4$ and $(a^x)^y = a^{xy}$ so $(10^8)^{1/4} = 10^2$

The final answer can be left in standard form rather than converting into an ordinary number

$$3 \times 10^2$$

(2)

(b) Find the value of $64^{-\frac{1}{2}}$

To the power of $1/2$ means the square root. The negative means reciprocal. $\sqrt{64} = 8$ then reciprocal means 1 over

$$\frac{1}{8}$$

(2)

(c) Write $\frac{3^n}{9^{n-1}}$ as a power of 3

$$(3^2)^{n-1}$$

← Writing the denominator as a power of 3. $9 = 3^2$

$$\frac{3^n}{3^{2n-2}}$$

← $(3^2)^{n-1} = 3^{2n-2}$ as $(a^x)^y = a^{xy}$. $2(n-1) = 2n-2$

$$n - (2n - 2)$$

← $a^x / a^y = a^{x-y}$ so the indices can be subtracted

$$n - (2n - 2) = n - 2n + 2 = 2 - n$$

$$3^{2-n}$$

(2)

(Total for Question 11 is 6 marks)

12 The table gives information about the weekly wages of 80 people.

Wage (£ w)	Frequency
$200 < w \leq 250$	5
$250 < w \leq 300$	10
$300 < w \leq 350$	20
$350 < w \leq 400$	20
$400 < w \leq 450$	15
$450 < w \leq 500$	10

(a) Complete the cumulative frequency table.

Wage (£ w)	Cumulative frequency
$200 < w \leq 250$	5
$200 < w \leq 300$	15 ← $5 + 10$
$200 < w \leq 350$	35 ← $15 + 20$
$200 < w \leq 400$	55 ← $35 + 20$
$200 < w \leq 450$	70 ← $55 + 15$
$200 < w \leq 500$	80 ← $70 + 10$

The frequencies are added up as they go

(1)

(b) On the grid opposite, draw a cumulative frequency graph for your completed table.

(2)

Juan says

“60% of this group of people have a weekly wage of £360 or less.”

(c) Is Juan correct?

You must show how you get your answer.

$$\frac{80}{10} \times 6 = 48$$

Dividing by 10 works out 10% of 80.
Multiplying by 6 works out that 60% is 48

No

From the cumulative frequency graph and assuming that the wages are evenly distributed through the $350 < w \leq 400$ interval, it is estimated that there were 39 with a wage of £360 or less. This is not 48

(3)

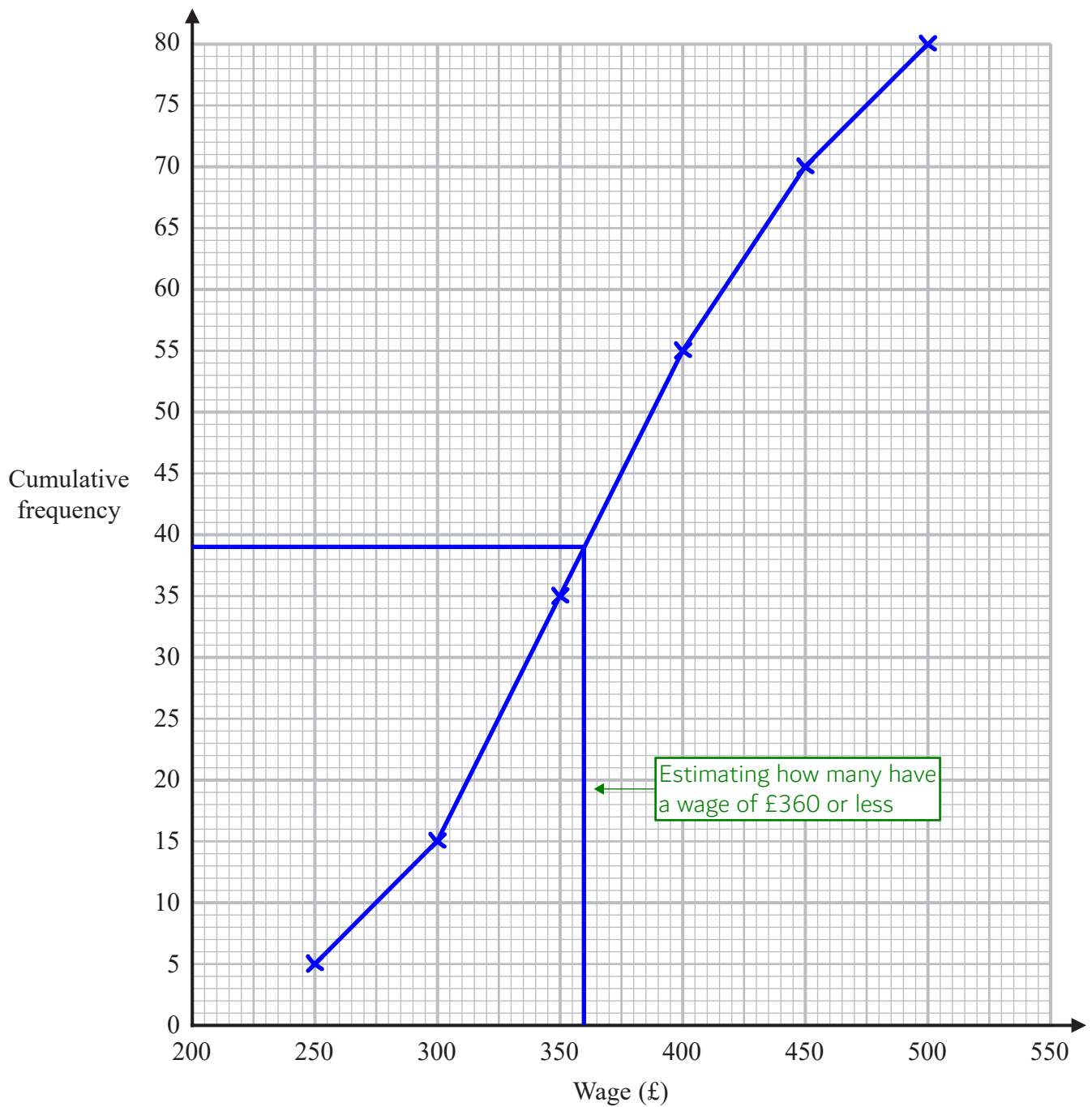

(Total for Question 12 is 6 marks)

The cumulative frequencies are plotted at the end of each interval. The points can be joined up with a series of straight lines

13 Liquid A and liquid B are mixed to make liquid C.

Liquid A has a density of 70 kg/m^3

Liquid A has a mass of 1400 kg

Liquid B has a density of 280 kg/m^3

Liquid B has a volume of 30 m^3

Work out the density of liquid C.

$d \begin{matrix} m \\ v \end{matrix}$ ← Writing a formula triangle for density, mass, volume

$$70 \overline{) 1400} + 30 = 50$$

Covering v in the formula triangle finds that volume = mass \div density.
Dividing the mass of A by the density of A finds that the volume of A is 30 m^3 . Adding the 20 m^3 volume of B finds that the volume of C is 50 m^3

$$\begin{array}{r} 280 \\ \times 30 \\ \hline 8400 \\ + 1400 \\ \hline 9800 \end{array}$$

Covering m in the formula triangle finds that mass = density \times volume. Multiplying the density of B by the volume of B finds that the mass of B is 8400 kg

Adding the 1400 kg mass of A to the 8400 kg mass of B finds that the mass of C is 9800 kg

$$50 \overline{) 9800}$$

Covering d in the formula triangle finds that density = mass \div volume.
Dividing the mass of C by the volume of C works out the density of C

.....196..... kg/m^3

(Total for Question 13 is 3 marks)

- 14 Sally plays two games against Martin.
In each game, Sally could win, draw or lose.

In each game they play,
the probability that Sally will win against Martin is 0.3
the probability that Sally will draw against Martin is 0.1

Work out the probability that Sally will win **exactly** one of the two games against Martin.

$$0.3 \times 0.7 + 0.7 \times 0.3$$

Win AND not win OR not win AND win. AND means to multiply the probabilities. OR means to add the probabilities. It is certain to either win or not win so the probability of not win is $1 - 0.3 = 0.7$

$$0.21 + 0.21$$

$3 \times 7 = 21$. There are 2 decimal places in total in 0.3 and 0.7. So bringing the decimal point in 21 2 places to the left finds that $0.3 \times 0.7 = 0.21$

0.42

(Total for Question 14 is 3 marks)

- 15 The straight line L_1 has equation $y = 3x - 4$
The straight line L_2 is perpendicular to L_1 and passes through the point (9, 5)

Find an equation of line L_2

$$y = \frac{-1}{3}x + c$$

The general equation of a straight line is $y = mx + c$, where m is the gradient and c is the y -intercept. The gradient of L_2 must be the negative reciprocal of the gradient of L_1 as they are perpendicular. The negative reciprocal of 3 is $-1/3$

$$c = 5 + \frac{1}{3}(9) = 8$$

Rearranged to make c the subject and substituting in the coordinates (9, 5). $c = y + 1/3 x$ and $x = 9, y = 5$

Substituting 8 for c in the original equation

$$y = \frac{-1}{3}x + 8$$

(Total for Question 15 is 3 marks)

16 Shirley wants to find an estimate for the number of bees in her hive.

On Monday she catches 90 of the bees.
She puts a mark on each bee and returns them to her hive.

On Tuesday she catches 120 of the bees.
She finds that 20 of these bees have been marked.

(a) Work out an estimate for the total number of bees in her hive.

$$\frac{20}{90}x = 120 \leftarrow \text{Let } x \text{ be the total number of bees. It can be estimated that she has caught } 20/90 \text{ of the total number of bees and this is } 120$$

$$120 \times \frac{90}{20} \leftarrow x = 120 \div 20/90 = 120 \times 90/20$$

$$\begin{aligned} 120/20 &= 12/2 = 6 \\ 6 \times 9 &= 54 \text{ so } 6 \times 90 = 540 \end{aligned} \rightarrow 540$$

(3)

Shirley assumes that none of the marks had rubbed off between Monday and Tuesday.

(b) If Shirley's assumption is wrong, explain what effect this would have on your answer to part (a).

It will decrease

If some of the marks have rubbed off, there will likely be more than 20 caught on Tuesday which are of the original 90 caught on Monday. This would mean that the total number of bees would be $120 \times 90 / (\text{something greater than } 20)$, which would be less than 540

(1)

(Total for Question 16 is 4 marks)

17 Make f the subject of the formula $d = \frac{3(1-f)}{f-4}$

$$d(f-4) = 3(1-f) \leftarrow \text{Multiplying both sides by } f-4 \text{ to eliminate the denominator}$$

$$df - 4d = 3 - 3f \leftarrow \text{Expanding the brackets}$$

$$df + 3f = 3 + 4d \leftarrow \begin{array}{l} \text{Adding } 3f \text{ to both sides to get all terms with } f \text{ on the same side.} \\ \text{Adding } 4d \text{ to both sides to get all terms without } f \text{ on the other side} \end{array}$$

$$f(d+3) = 3+4d \leftarrow \text{Bringing } f \text{ out as a factor on the left}$$

Dividing both sides by $d+3$ gets f on its own

$$f = \frac{3+4d}{d+3}$$

(Total for Question 17 is 4 marks)

18 x is proportional to \sqrt{y} where $y > 0$

y is increased by 44%

Work out the percentage increase in x .

$$\sqrt{\frac{144}{100}} \leftarrow \text{Expressing the percentage increase as a multiplier: } 144/100. \text{ The square root of the multiplier will happen to } x \text{ as } y \text{ is square rooted}$$

$$\frac{12}{10} \leftarrow \text{Square rooting the numerator gives } 12 \text{ and square rooting the denominator gives } 10$$

$$\frac{120}{100} \leftarrow \text{Multiplying both the numerator and denominator by } 10 \text{ to express the multiplier for } x \text{ as a fraction with } 100 \text{ as the denominator to work out what percentage it has increased to}$$

x has increased to 120% so has increased by 20%

$$20\%$$

(Total for Question 18 is 3 marks)

19 f and g are functions such that

$$f(x) = \frac{12}{\sqrt{x}} \quad \text{and} \quad g(x) = 3(2x + 1)$$

(a) Find $g(5)$

$$3(2(5) + 1) \leftarrow \text{Substituting 5 for } x \text{ in } g(x)$$

$$\begin{aligned} 2(5) &= 10 \\ 10 + 1 &= 11 \\ 3(11) &= 33 \end{aligned}$$

33

(1)

(b) Find $gf(9)$

$$\frac{12}{\sqrt{9}} \leftarrow \text{Substituting 9 for } x \text{ in } f(x). \sqrt{9} = 3 \text{ then } 12/3 = 4$$

$$3(2(4) + 1) \leftarrow \text{Substituting 4 for } x \text{ in } g(x)$$

$$\begin{aligned} 2(4) &= 8 \\ 8 + 1 &= 9 \\ 3(9) &= 27 \end{aligned}$$

27

(2)

(c) Find $g^{-1}(6)$

$$3(2x + 1) = 6 \leftarrow \text{The input of the inverse function } g^{-1}(x) \text{ is the output of the function } g(x)$$

$$2x + 1 = 2 \leftarrow \text{Dividing both sides by 3. The brackets are then no longer needed}$$

$$2x = 1 \leftarrow \text{Subtracting 1 from both sides gets the } x \text{ term on its own}$$

$$\text{Dividing both sides by 2 gets } x \text{ on its own. The input of the function } g(x) \text{ is the output of the inverse function } g^{-1}(x)$$

$\frac{1}{2}$

(2)

(Total for Question 19 is 5 marks)

DO NOT WRITE IN THIS AREA

DO NOT WRITE IN THIS AREA

DO NOT WRITE IN THIS AREA

20 Show that $\frac{\sqrt{180} - 2\sqrt{5}}{5\sqrt{5} - 5}$ can be written in the form $a + \frac{\sqrt{5}}{b}$ where a and b are integers.

$$5 \overline{) 180} \begin{array}{r} 36 \\ 150 \\ \hline 30 \end{array}$$

$\sqrt{180}$ must simplify to something $\sqrt{5}$ as the answer has $\sqrt{5}$ as the only surd. $\sqrt{180} = \sqrt{36 \times 5} = 6\sqrt{5}$

$$6\sqrt{5} - 2\sqrt{5}$$

Substituting $6\sqrt{5}$ for $\sqrt{180}$. This simplifies to $4\sqrt{5}$

$$\frac{4\sqrt{5}}{5\sqrt{5} - 5} \times \frac{5\sqrt{5} + 5}{5\sqrt{5} + 5}$$

Flipping the sign in the middle of $5\sqrt{5} - 5$ and multiplying both the numerator and denominator by $5\sqrt{5} + 5$ will rationalise the denominator

$$\frac{100 + 20\sqrt{5}}{125 + 25\sqrt{5} - 25\sqrt{5} - 25}$$

Multiplying the numerators and multiplying the denominators. Multiplying them in a similar way to expanding brackets. $\sqrt{5} \times \sqrt{5} = 5$

$$\frac{100 + 20\sqrt{5}}{100}$$

Simplifying the denominator

$$1 + \frac{\sqrt{5}}{5}$$

$100/100 = 1$ and $20\sqrt{5}/100 = \sqrt{5}/5$

(Total for Question 20 is 4 marks)

21 DEF is a triangle.

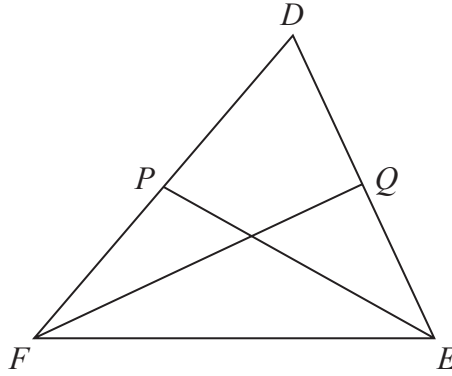

P is the midpoint of FD .
 Q is the midpoint of DE .

$$\vec{FD} = \mathbf{a} \quad \text{and} \quad \vec{FE} = \mathbf{b}$$

Use a vector method to prove that PQ is parallel to FE .

$$\vec{DE} = -\mathbf{a} + \mathbf{b} \quad \leftarrow \quad \boxed{\vec{DE} = \vec{DF} + \vec{FE}. \quad \vec{DF} = -\vec{FD} = -\mathbf{a}}$$

$$\vec{DQ} = -0.5\mathbf{a} + 0.5\mathbf{b} \quad \leftarrow \quad \boxed{\vec{DQ} = 0.5\vec{DE} \text{ as } Q \text{ is the midpoint of } DE}$$

$$\vec{PD} = 0.5\mathbf{a} \quad \leftarrow \quad \boxed{\vec{PD} = 0.5\vec{FD} \text{ as } P \text{ is the midpoint of } FD}$$

$$\vec{PQ} = 0.5\mathbf{a} - 0.5\mathbf{a} + 0.5\mathbf{b} \quad \leftarrow \quad \boxed{\vec{PQ} = \vec{PD} + \vec{DQ}}$$

$$= 0.5\mathbf{b} \quad \leftarrow \quad \boxed{\text{Collecting like terms}}$$

$$= 0.5\vec{FE} \quad \leftarrow \quad \boxed{\text{So } PQ \text{ is parallel to } FE \text{ as } \vec{PQ} \text{ is something multiplied by } \vec{FE}. \text{ They are in the same direction but are different sizes}}$$

(Total for Question 21 is 4 marks)

DO NOT WRITE IN THIS AREA

22 The diagram shows two shaded shapes, A and B.

Shape A is formed by removing a sector of a circle with radius $(3x - 1)$ cm from a sector of the circle with radius $(5x - 1)$ cm.

Shape B is a circle of diameter $(2 - 2x)$ cm.

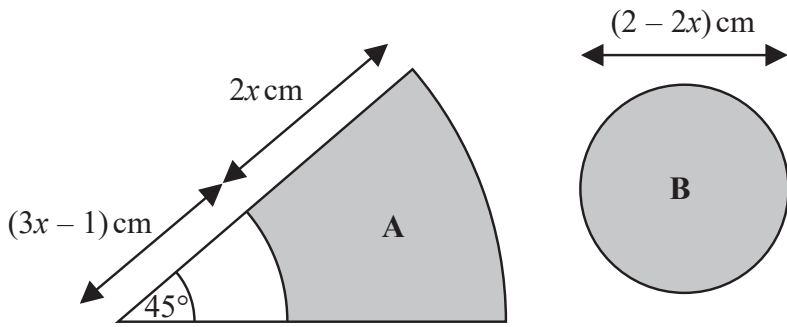

The area of shape A is equal to the area of shape B.

Find the value of x .

You must show all your working.

$$\frac{45}{360} = \frac{1}{8}$$

There are 360° around the centre of a circle. Expressing the 45° as a fraction of the 360° then simplifying the fraction by dividing both the numerator and denominator by 45. So the sectors are $\frac{1}{8}$ of the whole circles

$$(5x - 1)(5x - 1)$$

Area of circle = $\pi \times \text{radius}^2$. First working out radius^2 for the larger sector by multiplying the radius by itself

$$25x^2 - 5x - 5x + 1$$

Expanding the brackets

$$25x^2 - 10x + 1$$

Collecting like terms

$$(3x - 1)(3x - 1)$$

Area of circle = $\pi \times \text{radius}^2$. First working out radius^2 for the smaller sector by multiplying the radius by itself

$$9x^2 - 3x - 3x + 1$$

Expanding the brackets

$$9x^2 - 6x + 1$$

Collecting like terms

$$(1 - x)(1 - x)$$

Area of circle = $\pi \times \text{radius}^2$. First working out radius^2 for the circle B by multiplying the radius by itself. The radius is half of the diameter

$$1 - x - x + x^2$$

Expanding the brackets

$$1 - 2x + x^2$$

Collecting like terms

$$\frac{\pi(25x^2 - 10x + 1) - \pi(9x^2 - 6x + 1)}{8} = \pi(1 - 2x + x^2)$$

For shape A: subtracting the area of the inner circle from the area of the outer circle then doing $\frac{1}{8}$ of this works out the area of A. Area of circle = $\pi \times \text{radius}^2$. So multiplying the radius^2 found previously by π expresses the areas. Setting the area of A equal to the area of B

$$25x^2 - 10x + 1 - 9x^2 + 6x - 1 = 8 - 16x + 8x^2$$

π cancels out from all terms on both sides. Multiplying both sides by 8 to eliminate the denominator. $-(9x^2 - 6x + 1) = -9x^2 + 6x - 1$

$$\frac{1}{2}$$

(Total for Question 22 is 5 marks)

The method continues on the next page

DO NOT WRITE IN THIS AREA

DO NOT WRITE IN THIS AREA

$$8x^2 + 12x - 8 = 0 \leftarrow \text{Collecting all the terms onto the left so that it is in the quadratic form}$$

$$2x^2 + 3x - 2 = 0 \leftarrow \text{Dividing all terms on both sides by 4 to simplify}$$

$$(2x - 1)(x + 2) = 0 \leftarrow \text{Factorising. Double brackets are needed. } 2x \text{ must go in one bracket and } x \text{ must go in the other. The only ways of it expanding to give } -2 \text{ are if } 1 \text{ and } -2 \text{ or } -1 \text{ and } 2 \text{ are in the brackets. Putting } -1 \text{ with } 2x \text{ and } +2 \text{ with } x \text{ works as it would also expand out to give } +3x$$

$$2x - 1 = 0 \leftarrow \text{One of the two brackets must equal to } 0$$

$$2x = 1 \leftarrow \text{Adding } 1 \text{ to both sides gets the } x \text{ term on its own. Then dividing both sides by } 2 \text{ finds that } x = 1/2$$

$$x - 2 = 0 \leftarrow \text{One of the two brackets must equal to } 0. \text{ Adding } 2 \text{ to both sides finds that } x = 2. \text{ However substituting this into } 2 - 2x \text{ gives } 2 - 2(2) = -2 \text{ and length must be positive so this solution is ignored}$$

23 There are four types of cards in a game.

Each card has a black circle or a white circle or a black triangle or a white triangle.



number of cards with a black shape : number of cards with a white shape = 3:5

number of cards with a circle : number of cards with a triangle = 2:7

Express the total number of cards with a black shape as a fraction of the total number of cards with a triangle.

$$\frac{3}{8} \div \frac{7}{9}$$

3 out of the 8 parts in the ratio of the colours are black shapes. 7 out of the 9 parts in the ratio of the shapes are triangles. Expressing the fraction of the cards with a black shape ($\frac{3}{8}$) as a fraction of the fraction of the cards with a triangle ($\frac{7}{9}$)

$$\frac{3}{8} \times \frac{9}{7}$$

To divide fractions: keep the first number, change the division to a multiplication, flip the second fraction

To multiply fractions: multiply the numerators and multiply the denominators

$$\frac{27}{56}$$

(Total for Question 23 is 3 marks)

TOTAL FOR PAPER IS 80 MARKS